



Metropolitan Water Reclamation District of Greater Chicago

**Welcome to the October
Edition of the 2022 M&R
Seminar Series**

NOTES FOR SEMINAR ATTENDEES

- Remote attendees' audio lines have been muted to minimize background noise. **For in-person attendees, please silence your phones.**
- A question and answer session will follow the presentation.
- For remote attendees, Please use the "Chat" feature to ask a question via text to "Host". **For in-person attendees, please raise your hand and wait for the microphone to ask a question verbally.**
- The presentation slides will be posted on the MWRD website after the seminar.
- This seminar has been approved by the ISPE for one PDH and approved by the IEPA for one TCH. Certificates will only be issued to participants who attend the entire presentation.

Bruce Johnson, P.E., BCEE, IWA Fellow



Mr. Bruce Johnson is a wastewater technology senior fellow with Jacobs located in Denver. He has been doing wastewater treatment design for over 30 years, the last 27 of which has been with CH2M/Jacobs where he has held the roles of wastewater process and simulation global technology leader.

He has been active outside of Jacobs both in WEF and IWA. Within WEF, he has led and contributed the development of a number of MOPs and helped found the MEGA group. Within IWA, Mr. Johnson is a past scientific chair of WWTmod and a founding member of the IWA Design and Operations Uncertainty Task Group.

Digital Twin Development Implementation, and Results for the Changi WRP, Singapore

by Bruce R. Johnson, PE, BCEE, Raja Kadiyala, Ph.D., Garret Owens, Yin Ping Mak, Priska Grace, Colin Newbery, Sean Sing, Cheng Yang, Jack Greene

MWRDGC: October 28th, 2022

What Is Driving Retooling of Wastewater Infrastructure?

- Addressing today's issues...
- Aging infrastructure
- Service area changes
- Climate stress
- Increased regulation
- Space limitations
- Improved O&M efficiencies
- Water equity and community impacts
- Insufficient funding

While positioning for the future...



Attributes of the Plant of the Future

(WERF OWSO4R07d)

- Highly stringent regulatory requirements
- Carbon neutral; energy self-sufficient
- Centralized and decentralized systems
- Resource recovery center
- Community asset with social value
- Digitally enabled: Fully automated, minimum human operational interface



Managing the water sector through data-driven approaches and solution sets

- Water sector has recognized the need to use the interconnectivity associated with the water cycle...but didn't have the skills/tools to act
- Through SCADA, Utilities have collected large amounts data that go mostly unused
- However:
 - Knowledge base has expanded
 - Data management has improved
 - Computing power has caught up
- We can now integrate domain expertise, data management capabilities, and computational power with collected data to:

Evaluate, Design and Operate OneWater Solutions



Urban Wastewater Management Trends: Digital Water

- Turning Big Data into Actionable Information
- Presentation Agenda
 - Introduction into Wastewater Simulation
 - Advanced Controls
 - What is a Wastewater Digital Twin?
 - Singapore Changi WRP Digital Twin Project
 - Wrap-up

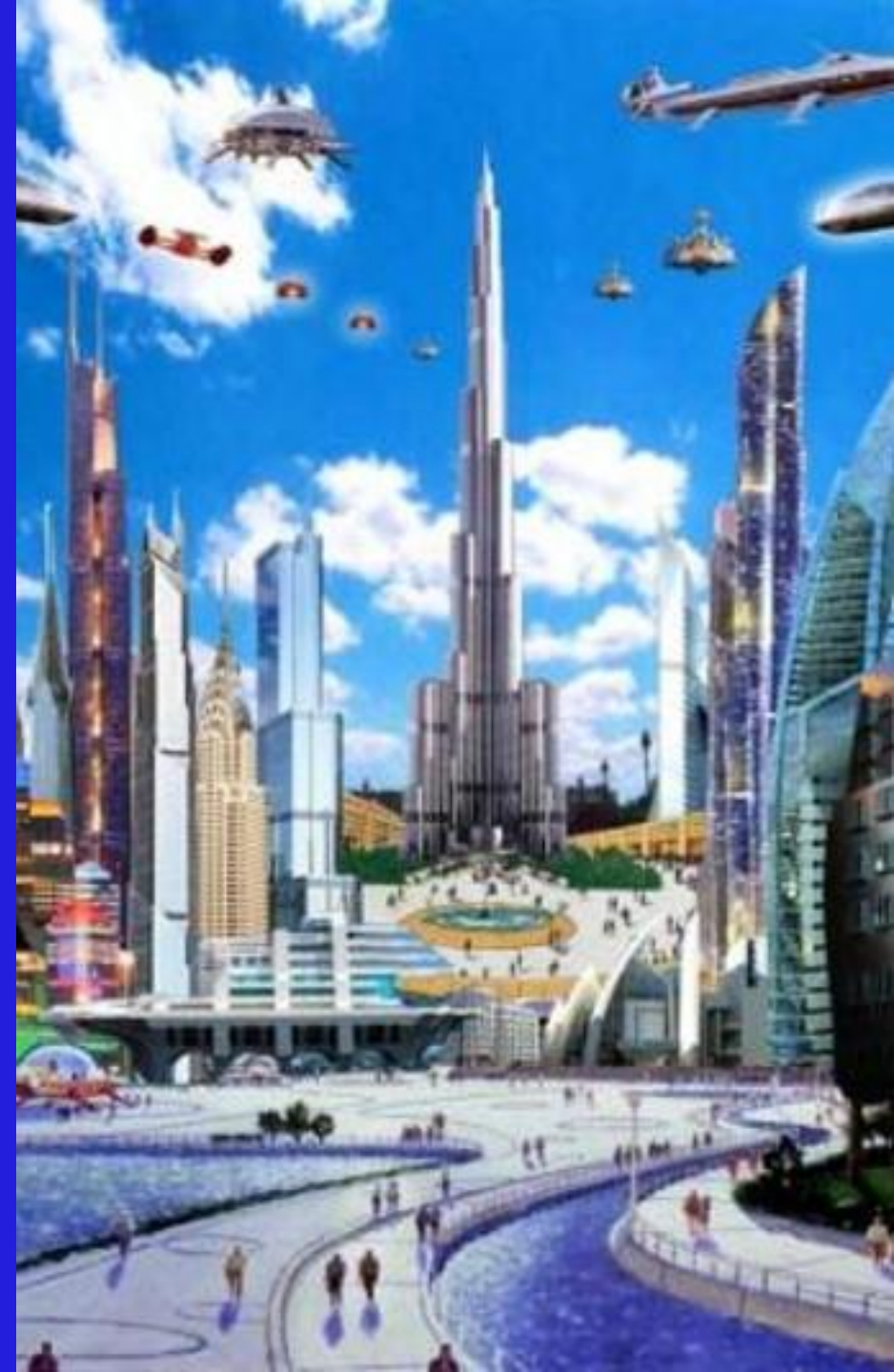

Introduction Into Wastewater Simulation



There are a wide variety of Wastewater Simulation Programs

- These programs, both commercial and private, simulate wastewater process throughout the whole plant
 - Some can model the whole watershed
 - Focused on Chemistry, Biochemistry, Physical Separation, and Oxygenation
- Each Simulator has its own unique strengths and weaknesses

The logo for WEST, consisting of the word "WEST" in a light blue, sans-serif font on a white rectangular background.The GPS-X logo features the text "GPS-X" in a blue, serif font with a trademark symbol, set against a light blue background.The SIMBA#water logo includes a blue circular icon with a white water drop, followed by the text "SIMBA#water" in a blue, sans-serif font.

STOAT

The eawag ASIM Software logo features the word "eawag" in a blue, sans-serif font above "aquatic research" in a smaller blue font, and "ASIM Software" in an orange font below.The Aquifas logo consists of the word "Aquifas" in a white, sans-serif font on a dark grey rectangular background.

REPLICA™



Wastewater Simulation has been advancing rapidly

- Biofilm/Granular sludge performance and settling
- Sulfur Chemistry
- Inorganic Precipitation: Struvite, Vivianite, Calcium Phosphate, Iron Sulfide, etc.
- Oxidation and Reduction Chemistry
- Energy modeling
- Gas phase modelling
- Control System Modelling
- Odor Generation
- Integrated Modelling: Collection system, Plant, and River in one model
- Uncertainty Quantification: Monte Carlo tools and risk/benefit analysis

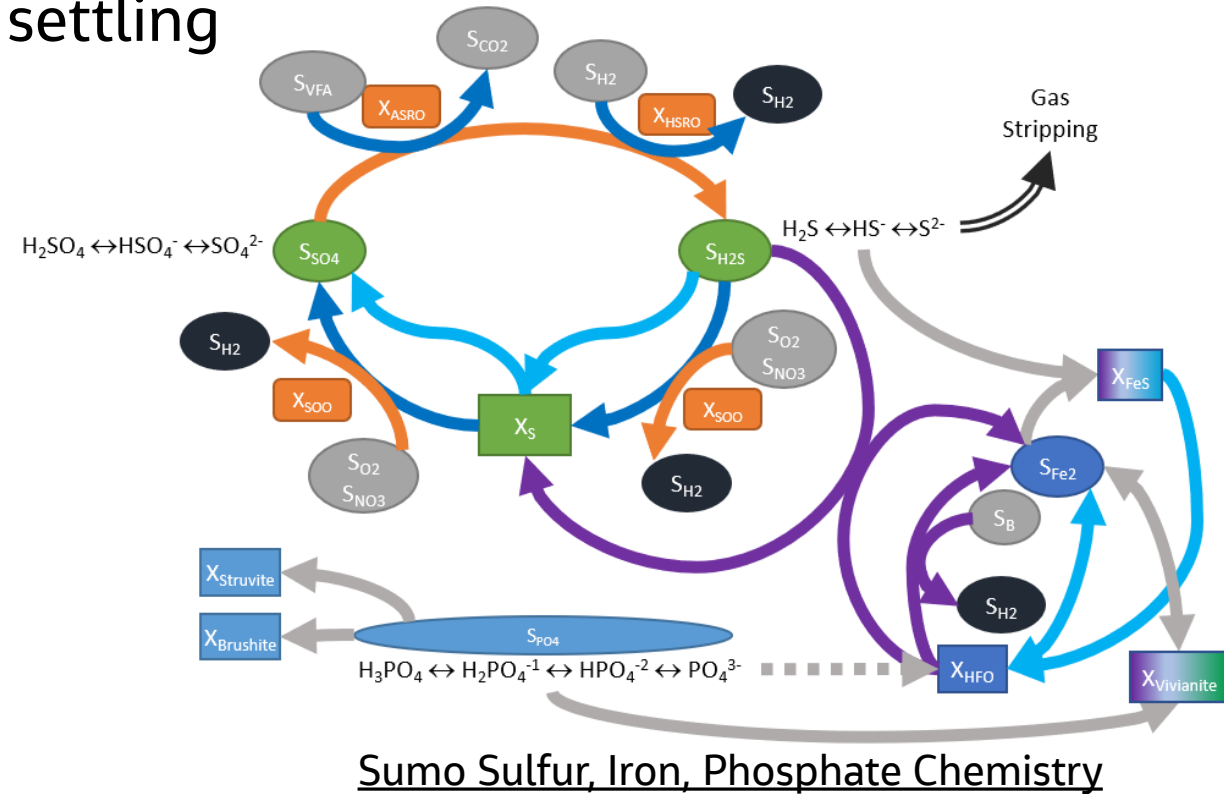

Advanced Controls/Digitalization



Too Much of a Good Thing? Wastewater Treatment and Big Data

- Almost all utilities have more data than they can effectively use
- It is very difficult to put all the data in context of the whole plant and needs to make immediate decisions
- So the issue becomes ones of using data effectively and in a timely manner

- Utilities have mountains of data and are looking to maximize value
 - Speed up decision making
 - Do more with less

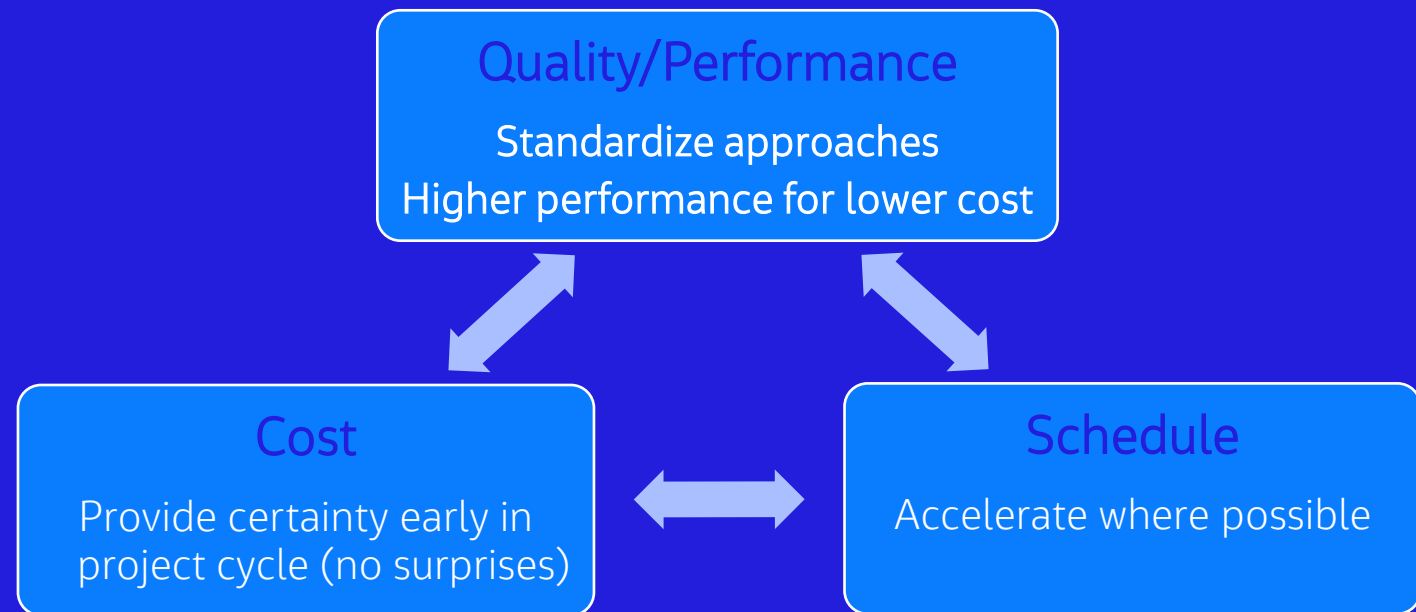

Automation is an Effective Method of Increasing Efficiency

- **On-Line controls can react moment by moment to improve operations and reduce operating costs**
 - Reduce air usage and associated energy
 - Improve nutrient removal
 - Reduce chemical usage
 - More efficient operation with less manpower
- **Advanced controls can be implemented to different degrees:**
 1. PID Control: Typical in industry with On-Line Instrumentation
 2. Model Based Control: Model is used in with online data to optimize operations
 3. Digital Twins: Live whole plant data feed, soft sensors, and predictive operations
 - ***Moving from Reactive to Proactive operations!***

What is a Soft-Sensor?

A “soft-sensor” uses a model to estimate what a sensor might have read, without needing a physical sensor

Digital Twins offer the Potential for Both Higher Efficiency and Reduced Instrumentation

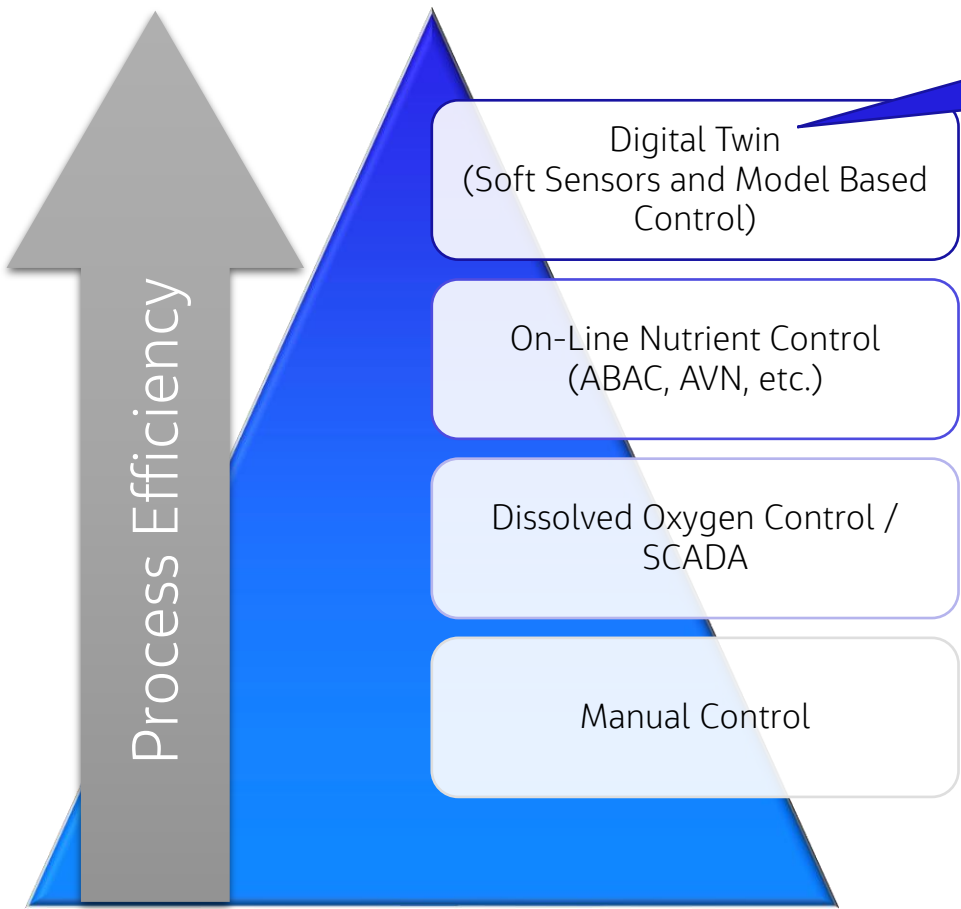

Can *REDUCE* instrumentation needs

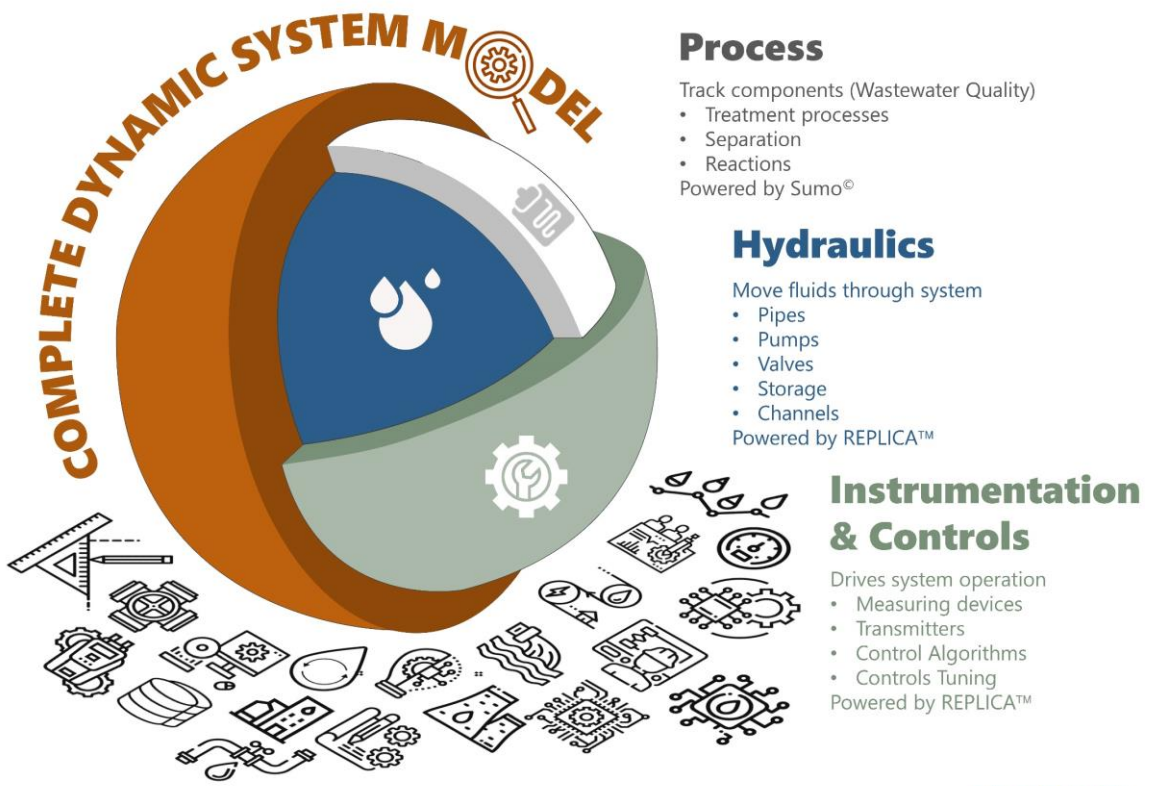

What is a Digital Twin?



What is a Digital Twin?

- A **digital representation** of a physical system **coupled with real-time data**, that can be used for synthetic data generation, scenario analysis, performance prediction and operational optimization
- It is more than “just” a fancy model, it has automated real-time data input



Digital Twin Market and Growth

Market Size	2016	2019	2027	CAGR (2020-2027)
2016-2027	USD 1,948.3 Million	USD 3,878.5 Million	USD 64,288.9 Million	43.8%
Market size by End Use	End Use	2019	2027	CAGR (2020-2027)
	Manufacturing	21.51%	14.08%	36.4%
	Agriculture	7.28%	11.92%	53.0%
	Automotive & Transportation	17.82%	31.17%	54.2%
	Energy & Utilities	10.56%	11.78%	45.8%
	Healthcare & Life Sciences	4.99%	4.17%	40.7%
	Residential & Commercial	24.88%	19.15%	39.2%
	Retail & Consumer Goods	3.33%	4.51%	49.3%
	Others	9.63%	3.21%	23.1%
Market Drivers	The global Digital Twins market is expected to grow significantly over the forecasted period in line with the growing need to ensure cost-efficient operations, optimize processes, and reduce the time to market as well as the growing adoption of IoT, cloud computing, and big data analytics.			

Benefits of a Digital Twin of a Complex System

- Simulate all aspects of a new or existing process system allows for more in depth knowledge and exploration which leads to cutting-edge solutions and more informed decision making.
 - Test hypothesis in a safe, low-cost environment
 - Improved system understanding, and communication, by many stakeholders
 - More robust solutions
 - Reduce operational risks
 - Reduce start-up risk and schedule
 - Increase facility performance efficiency



Digital Twin Architecture

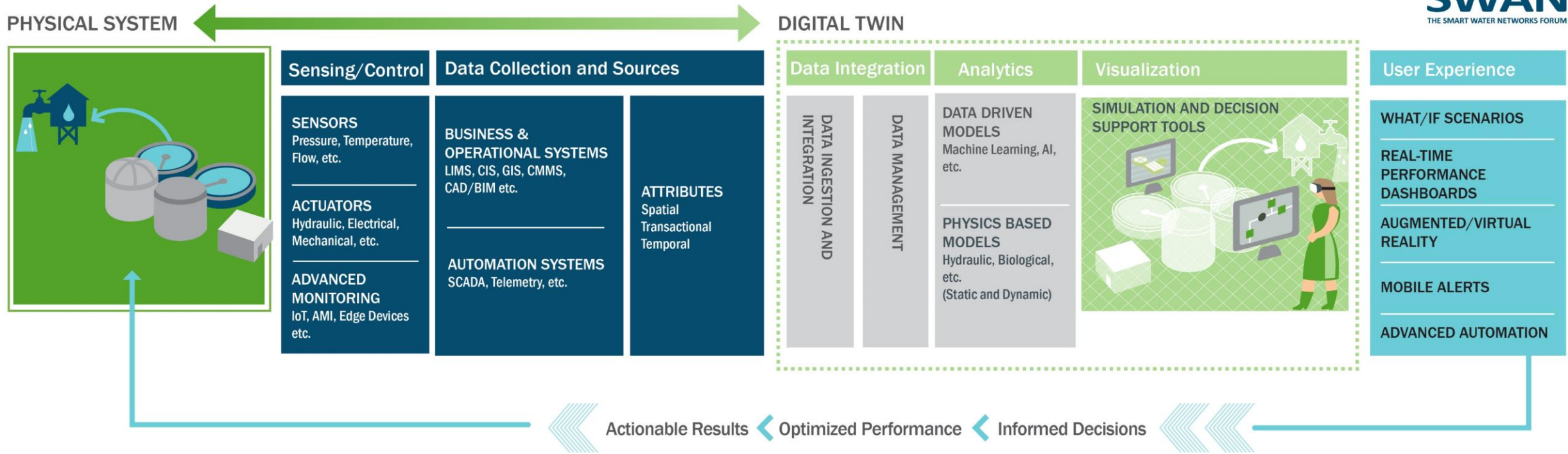

Secure and Connected Utility

Digital Twin Approach

Establish Business Case

Ensure Digital Twin adoption is driven by clear business needs

Define Insights

Incorporate performance metrics to meet stakeholder expectations

Identify Champions

To be trusted, the Digital Twin must be owned and actively managed

Enable Digital Twins

Single source of truth

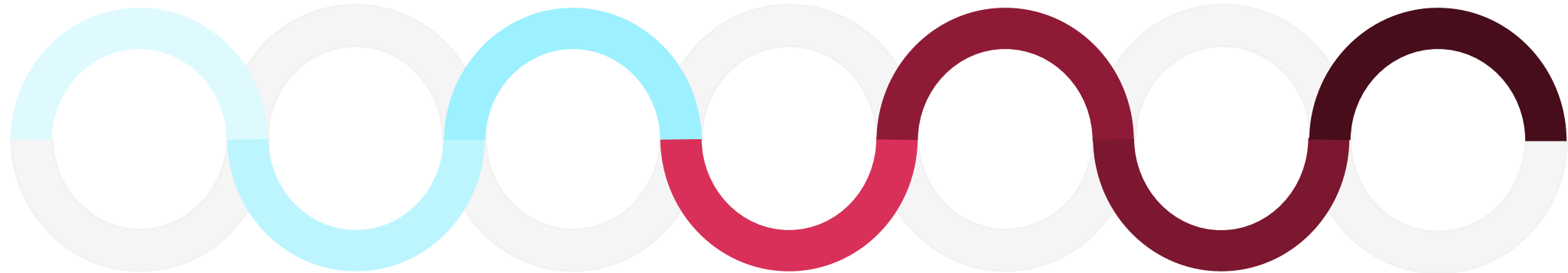

Understand Deliverables

Make sure the level of digitalization matches the organization's readiness

Technology

Establish which digital tools should be utilized to facilitate the process

Connect Data

Leverage the 'big data' used to inform the people, process, and technology

Singapore Changi WRP Digital Twin Project



Changi Water Reclamation Plant (CWRP) Singapore



- Operated by Singapore Public Utilities Board (PUB)
- Currently treating an average of approximately 920,000 m³/d (240 MGD) of used water
- Fed by a deep-tunnel sewer system
- Currently four bioreactor trains. Each train includes primary treatment and a parallel MBR and 5-pass step-feed bioreactor
- Most effluent is used for indirect potable reuse
- Solids include thickening, mesophilic anaerobic digestion, dewatering and drying

Changi WRP Digital Twin Research Project

- A research collaboration between PUB and Jacobs in the development and application of a Digital Twin of CWRP
- The Digital Twin includes models of:
 - Full plant Hydraulics (liquids and solids)
 - All major process controls
 - Biochemical Process
- All implemented on a dedicated server with real-time data feed

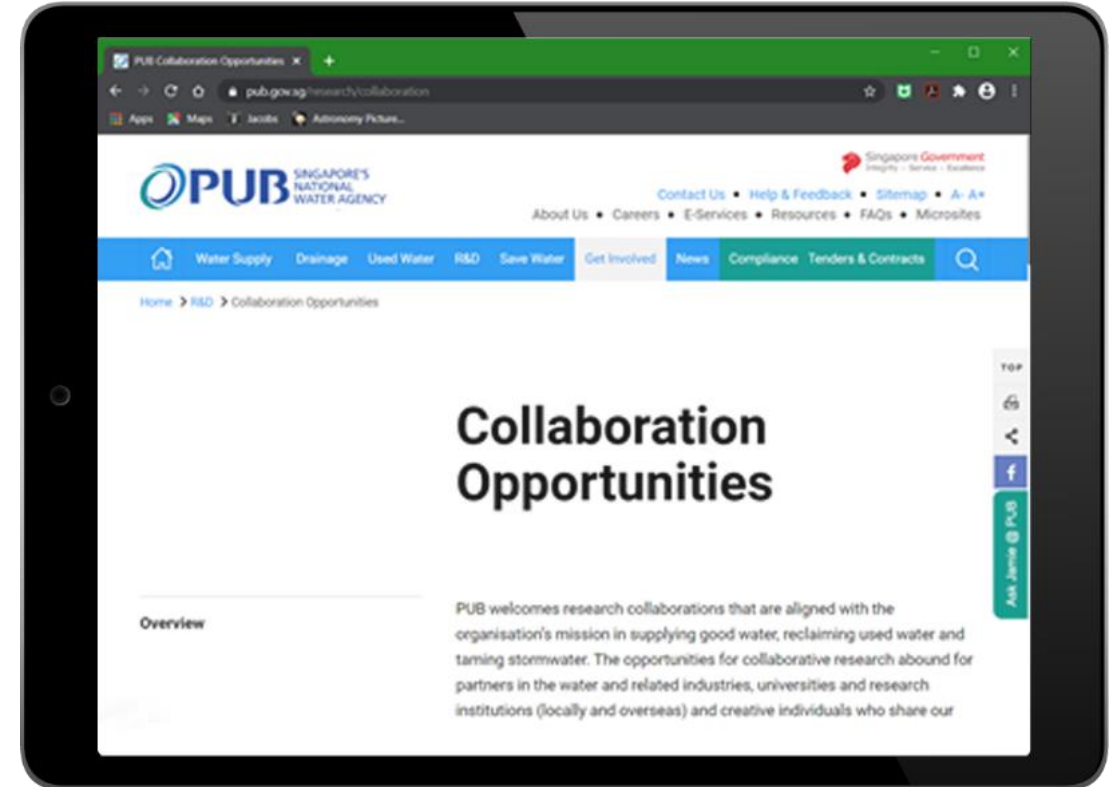

Overall CWRP Digital Twin Structure

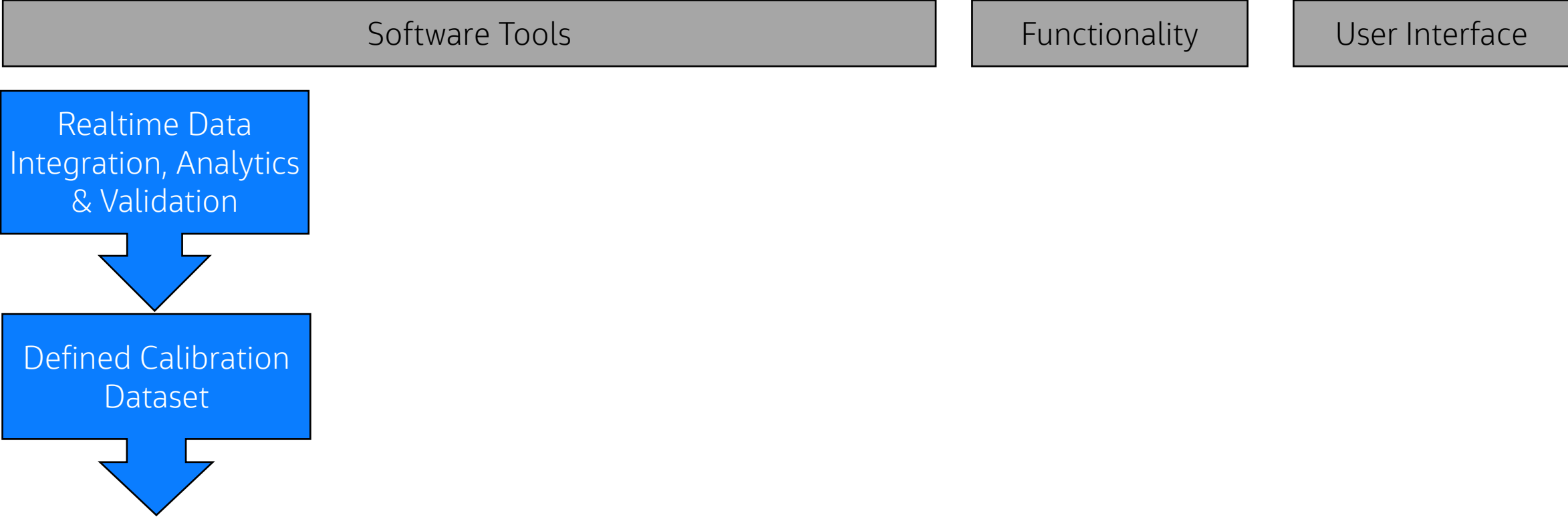

Overall CWRP Digital Twin Structure

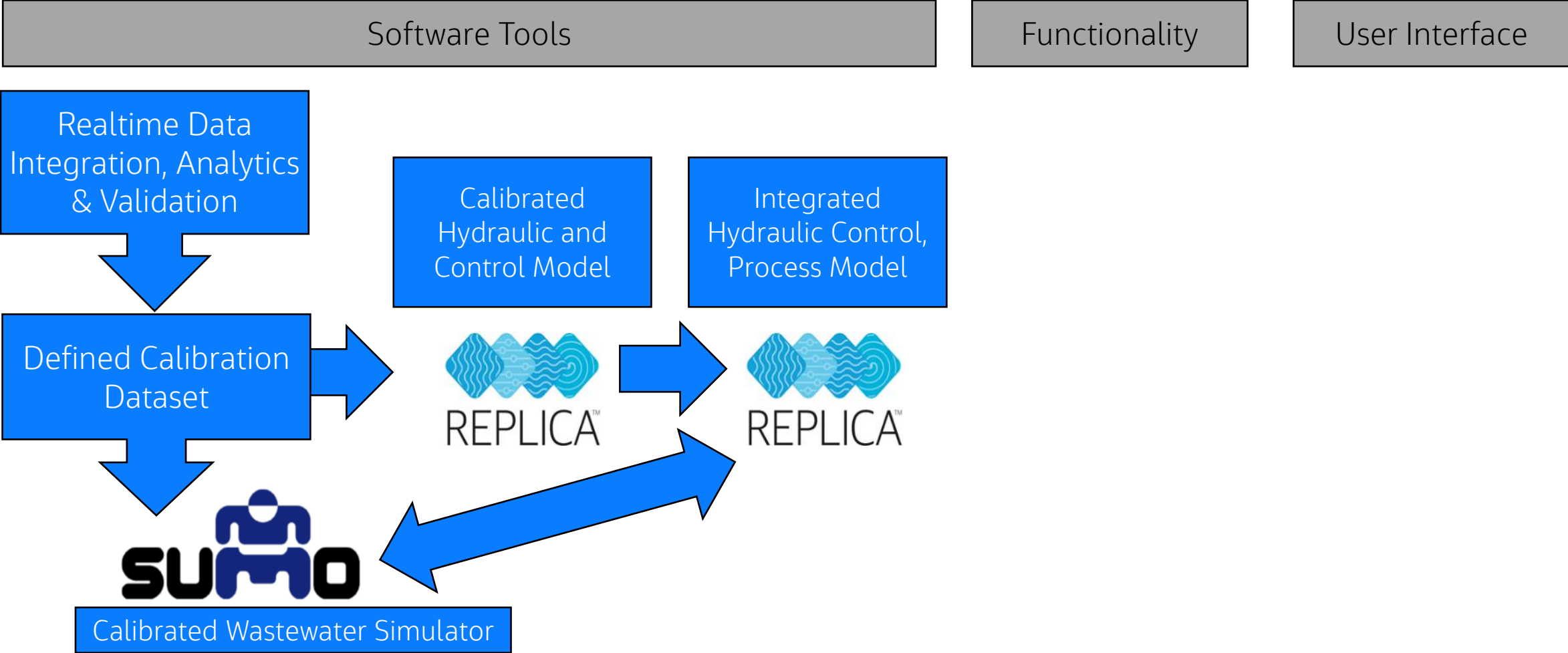

Overall CWRP Digital Twin Structure

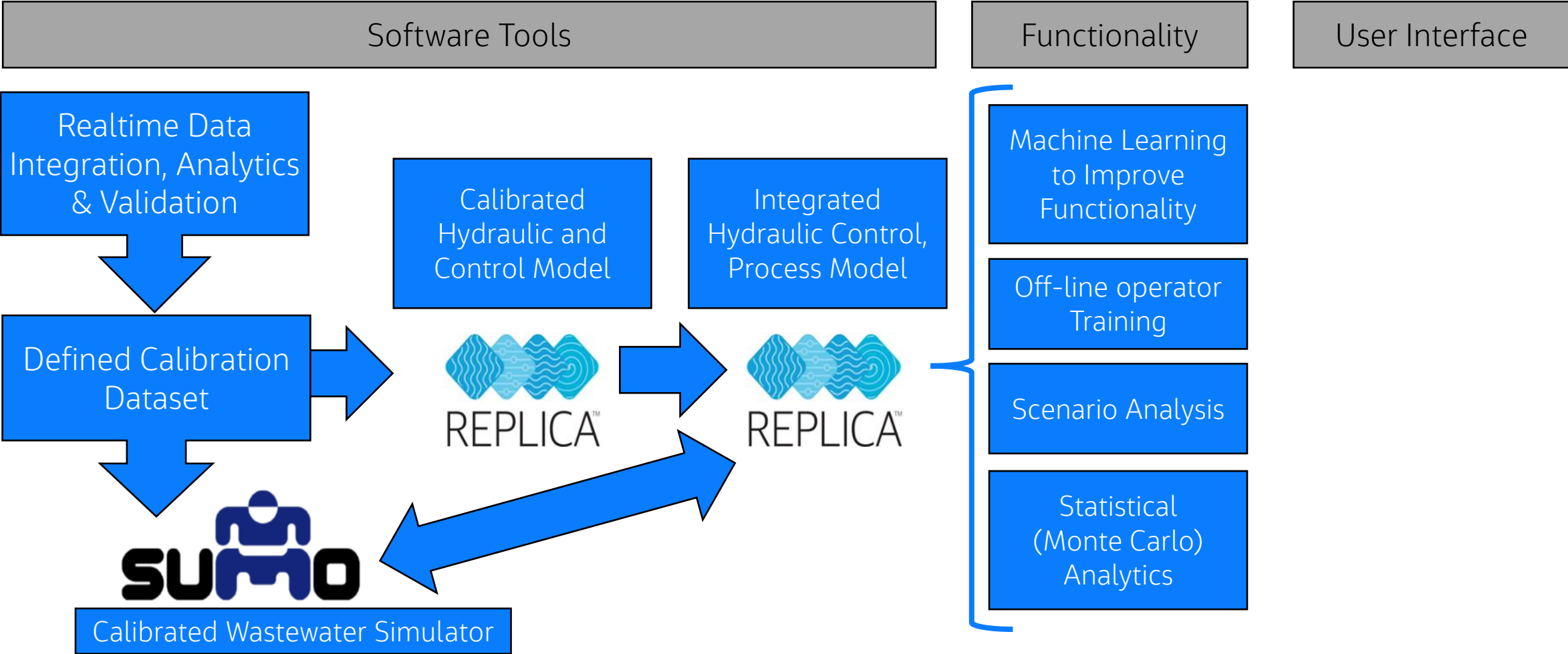

Overall CWRP Digital Twin Structure

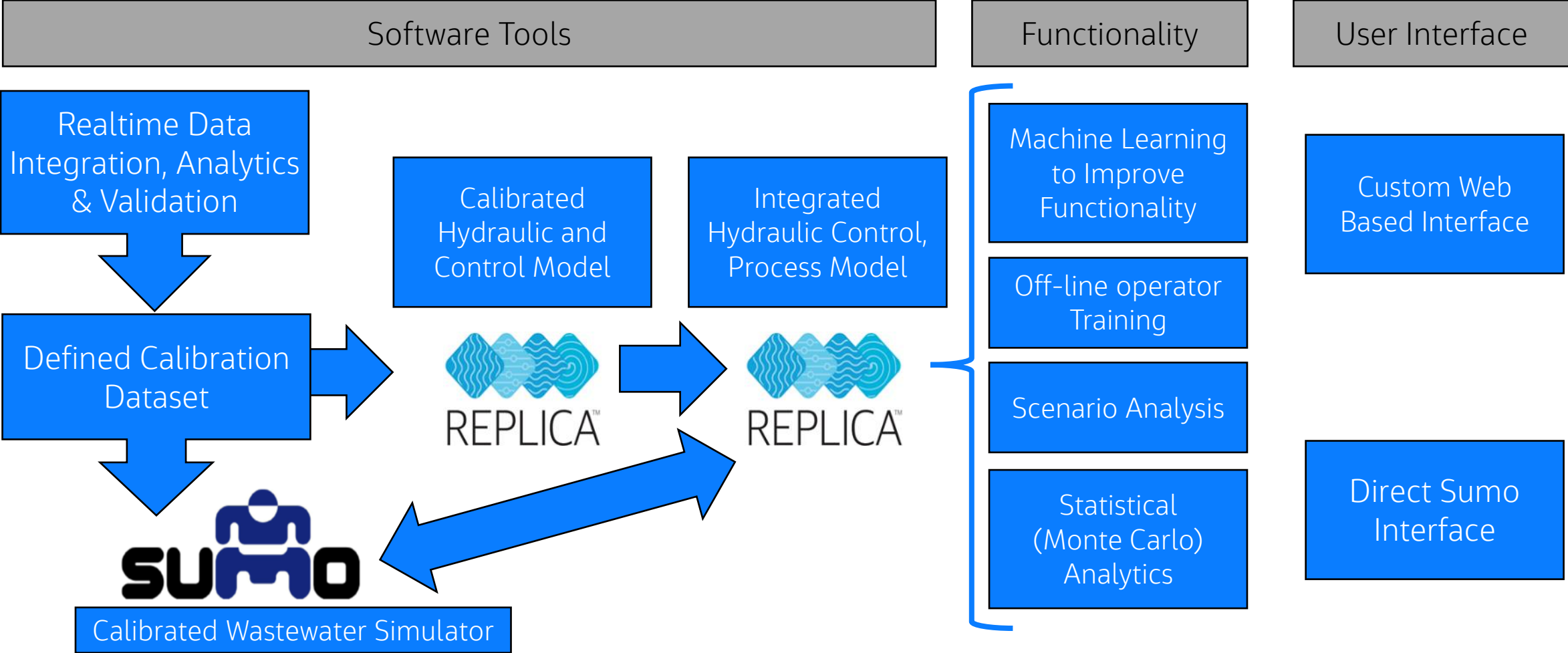

Changi WRP Process Flow Diagram Overview

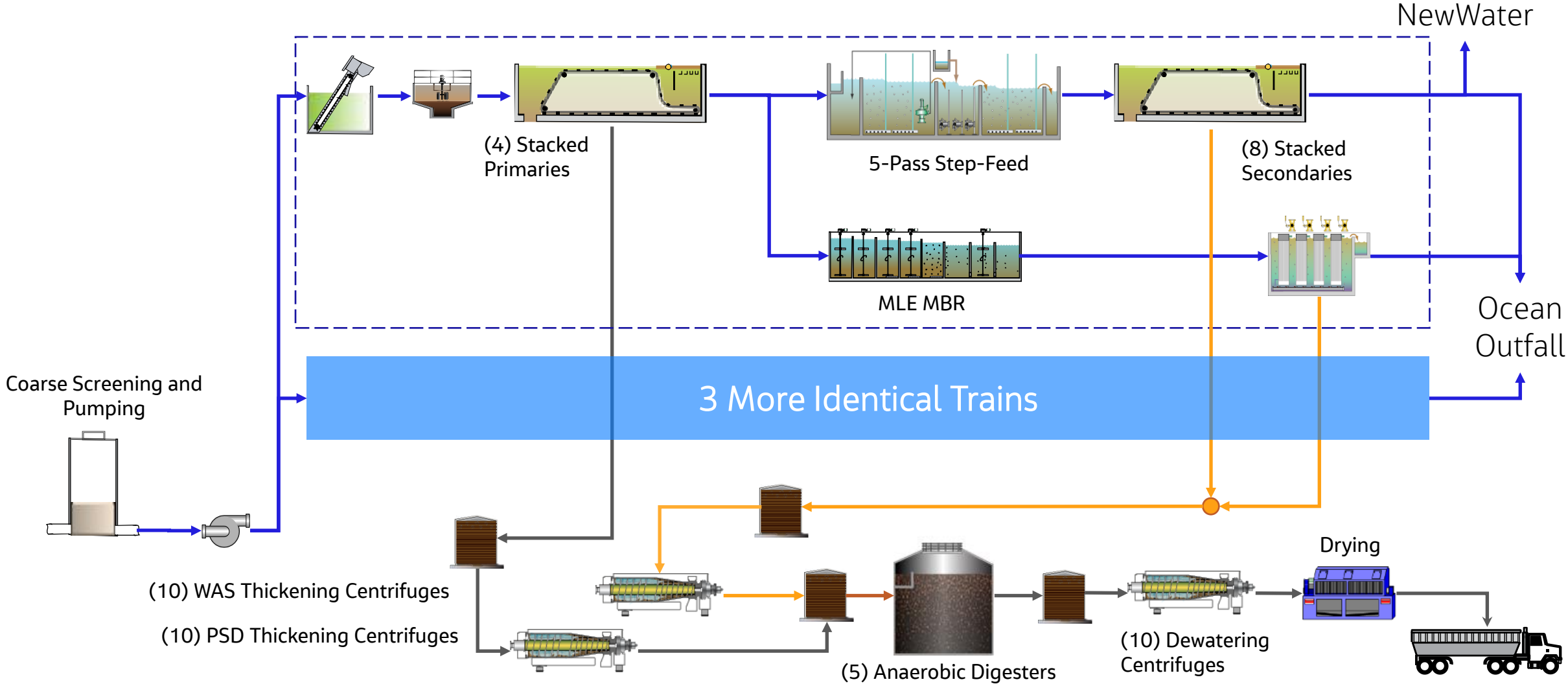

CWRP Sumo Process Model – Full Plant

- 169 biological reactors and imports 1,200 SCADA/LIMs tags

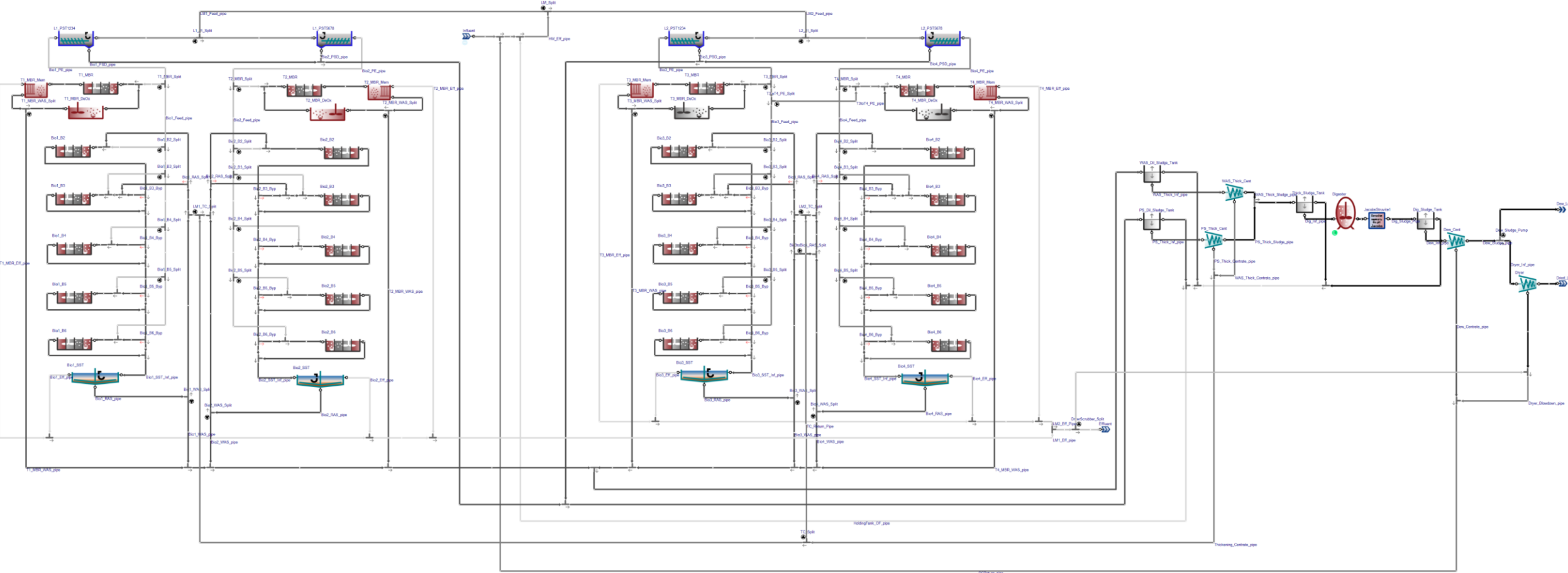

CWRP Sumo Process Models - Reduced

- Reduced Models, with settings from full DT Model are used for Scenario Analysis and Performance Forecasting

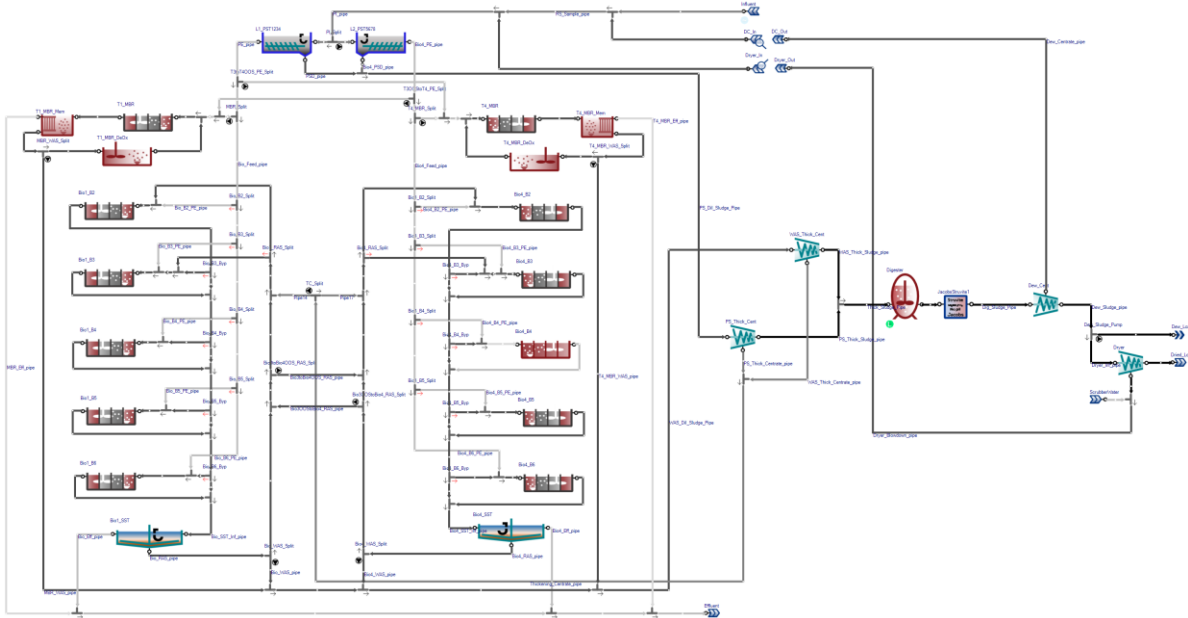

Scenario Evaluation Model

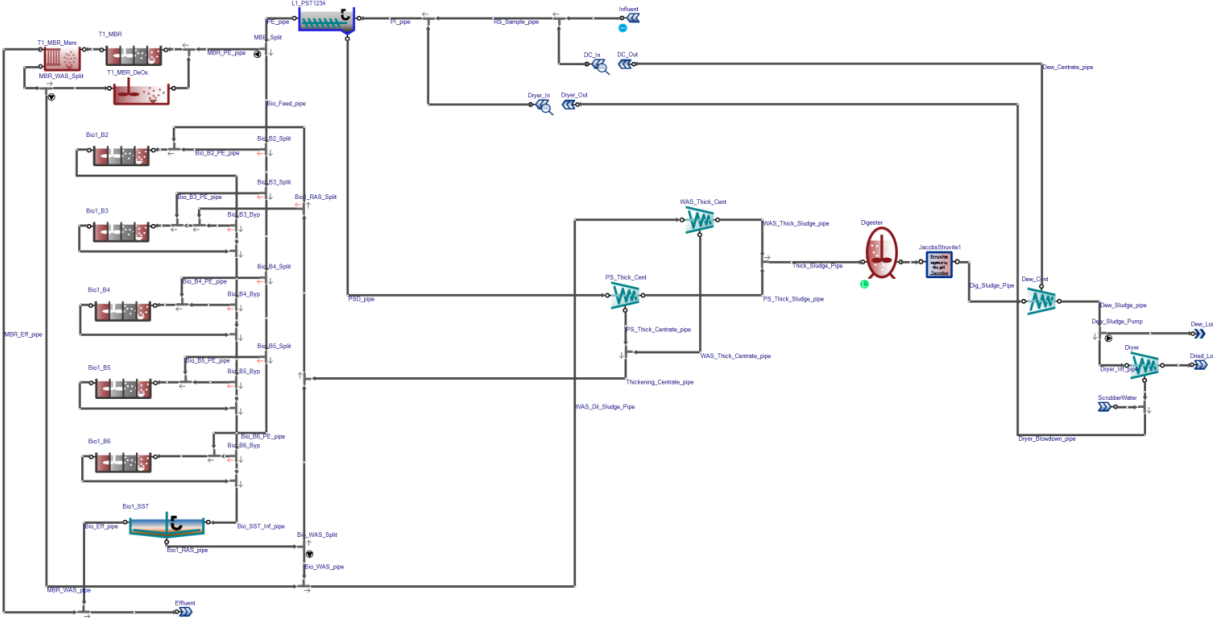

Performance Forecasting Model

Live Automated Data feed defines a Digital Twin

- Outlier detection – identify anomalous data through various analytical methods
- Infilling: Both on-line and laboratory bad/missing data
- Process Deviations

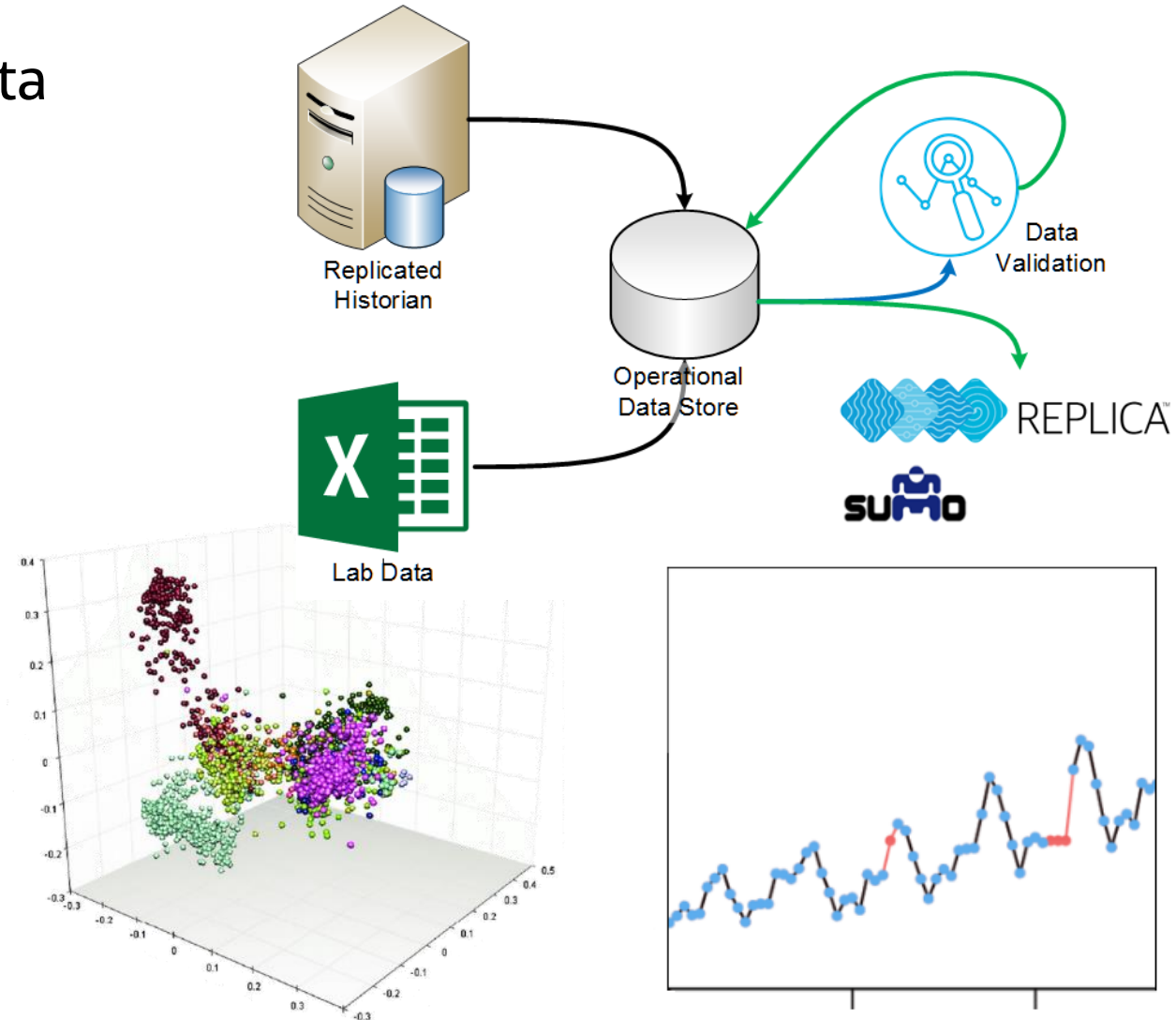
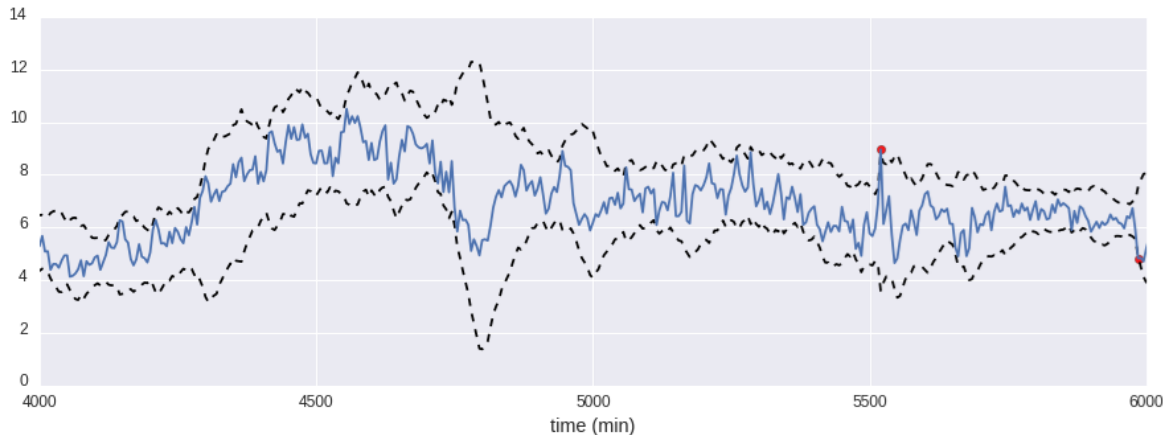

CWRP Influent Soft Sensor

- Use the model to estimate dynamic raw influent concentrations:
based on data from other locations
- Minimizes Instrumentation

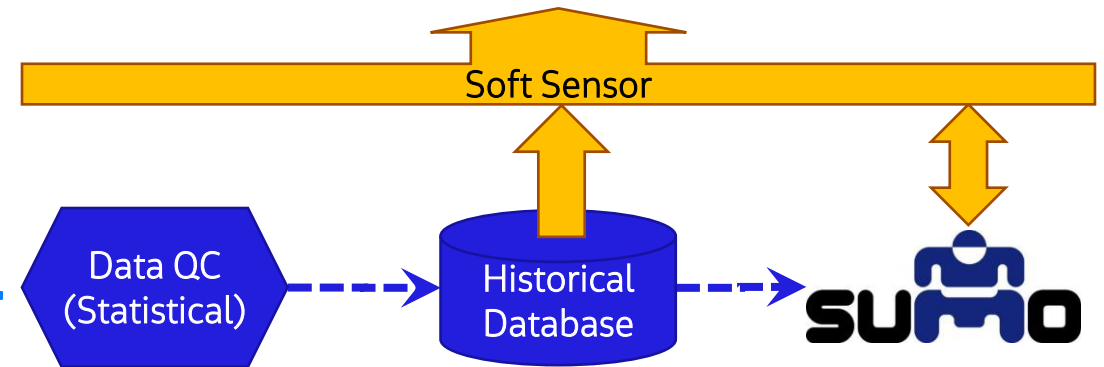
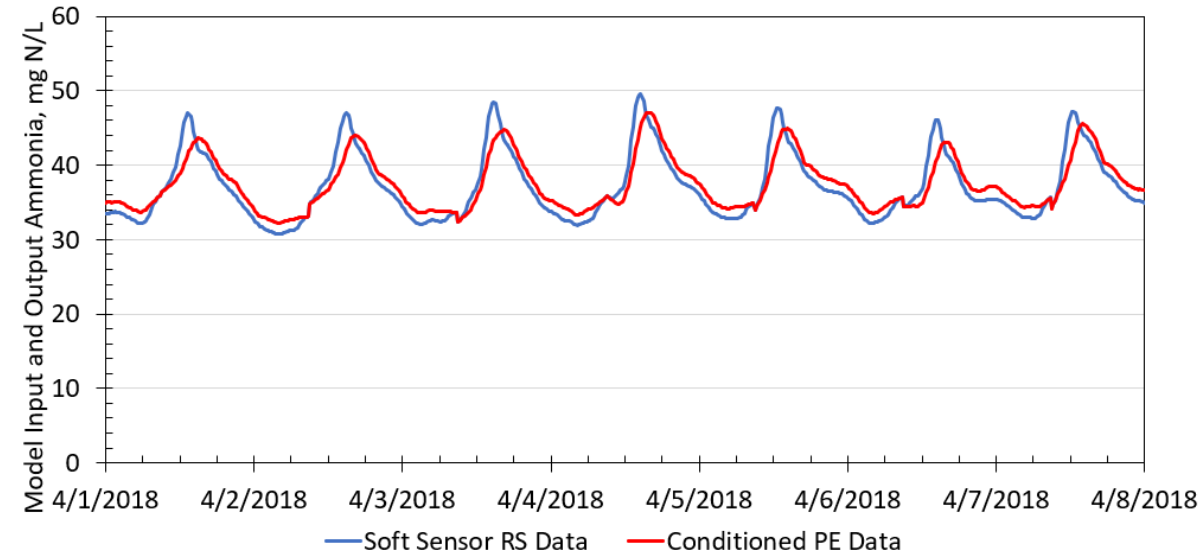
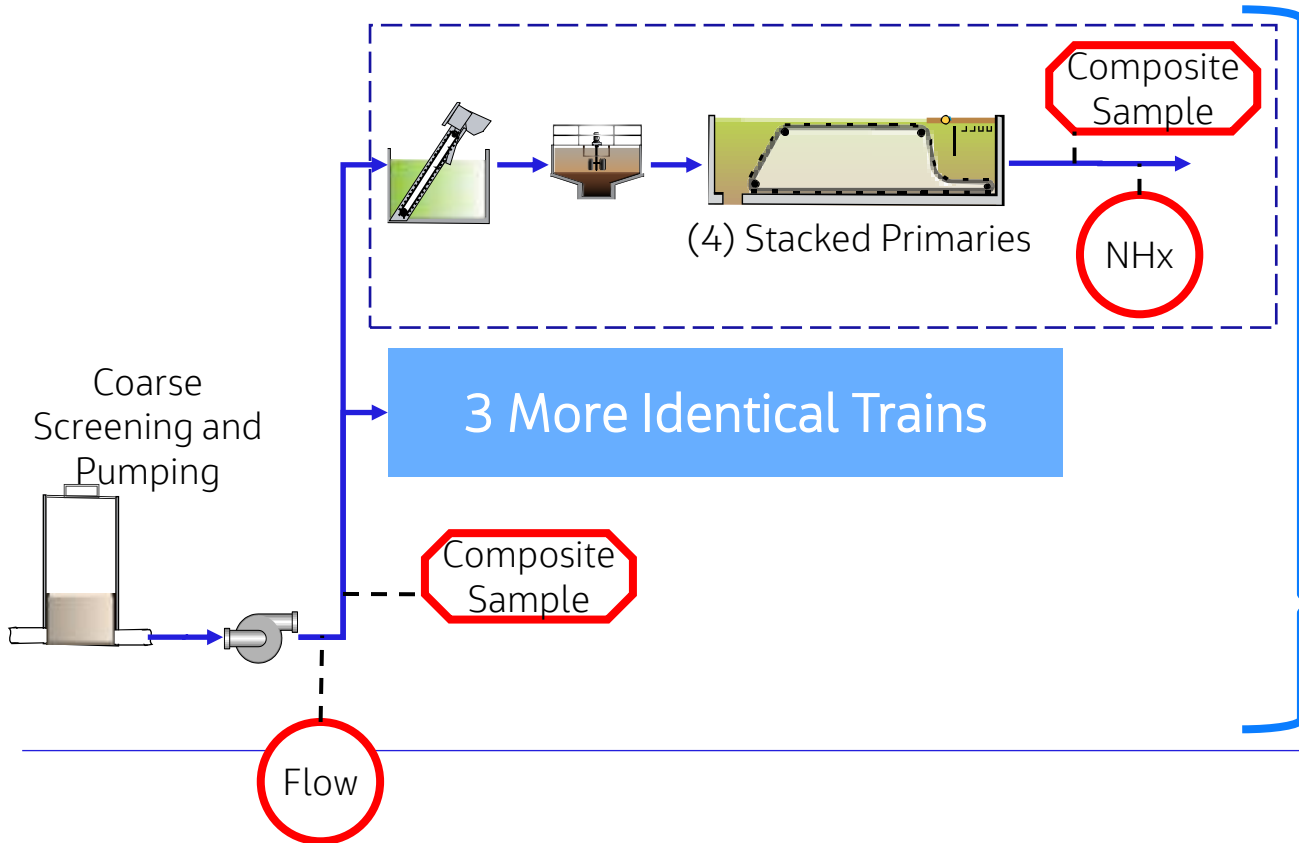

Influent Soft Sensor Results

- 6 months of results
- Blue dots are measurements
- Orange are daily average results
 - Top: COD
 - 2nd: TKN
 - 3rd: Ammonia
 - 4th: Total Phosphorus

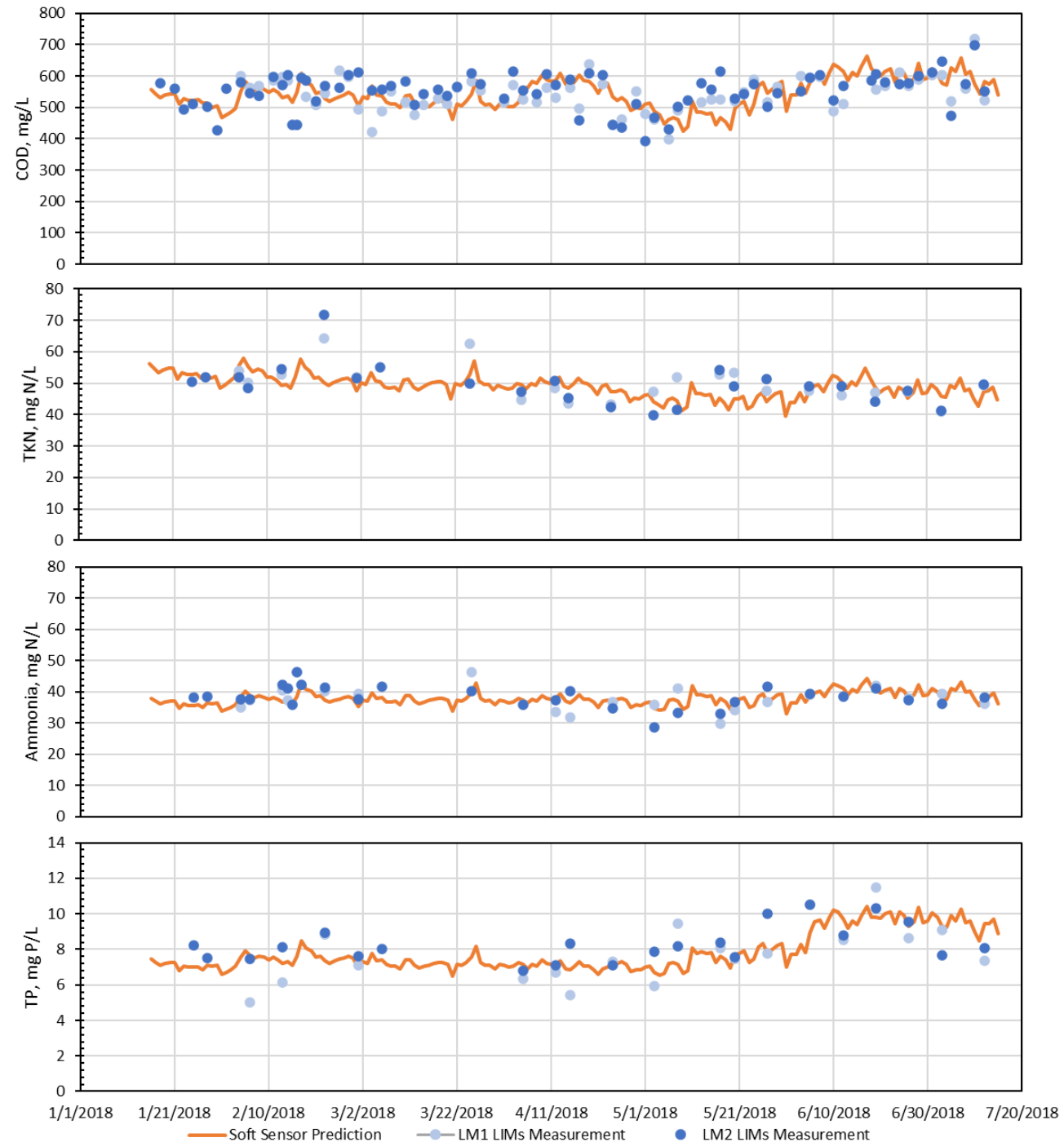

Actual Soft-Sensor Data has much more dynamic information

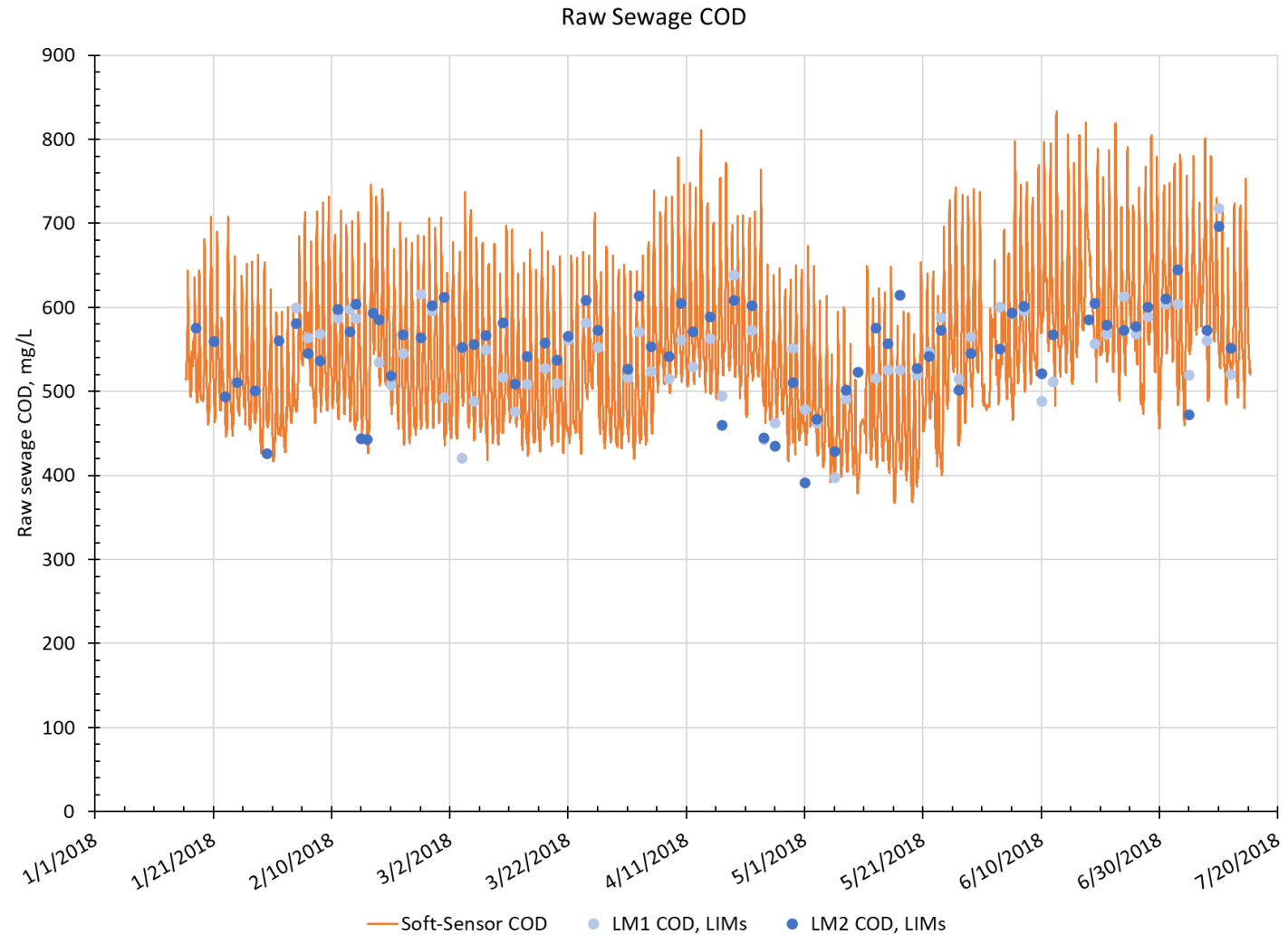

- Previous COD graph was the average of the dynamic values
- Dynamic data can provide much more insight into operational issues

Full Digital Twin Model Results

- Influent from the Soft sensor is fed into the full Digital Twin and model results are compared against historical measured values
- Results are plotted on the operations graphical user interface

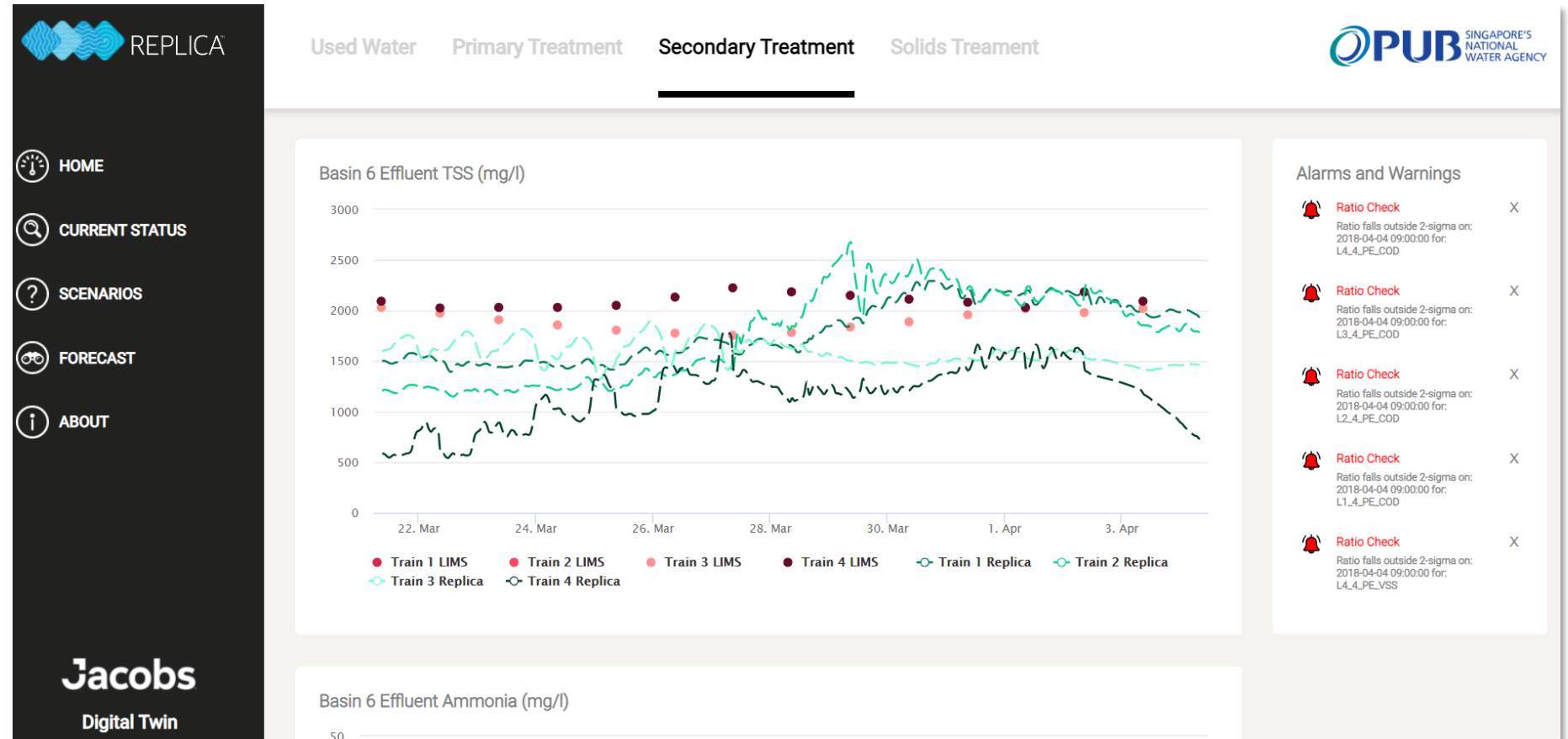

Scenario Evaluation

- Each day, three operational scenarios are automatically evaluated to provide operations with information on the ability of the plant to handle planned and unplanned outages
 - A basin is taken out of service
 - A secondary settling tank is taken out of service
 - WAS is limited/halted

Scenario 1 Scenario 2 Scenario 3

Scenario 1 - Bio Basin Out of Service (OOS)

OOS Bio:

0 1 2 3 4

Maximum flow to OOS Bio (CMD):

180000

Flow splits within OOS Bio:

Basin 2: 0%

Basin 3: 0% - Currently OOS

Basin 4: 25%

Basin 5: 25%

Basin 6: 25%

Save Scenario 1 Data

Results:

Effluent Ammonia, SNHx (mg/l)

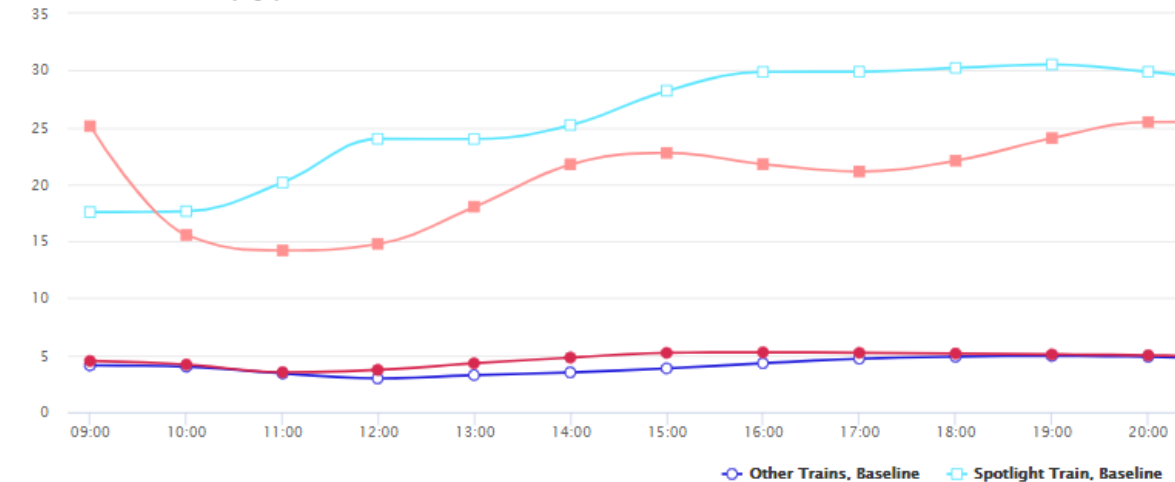

Other Trains, Baseline Spotlight Train, Baseline

CWRP Influent Flow Forecasting

- Manual Influent Pump Station Control
 - very difficult to predict
- Use Deep Tunnel level and pumped flow with a tunnel volume model to predict “normal” diurnal influent into tunnel

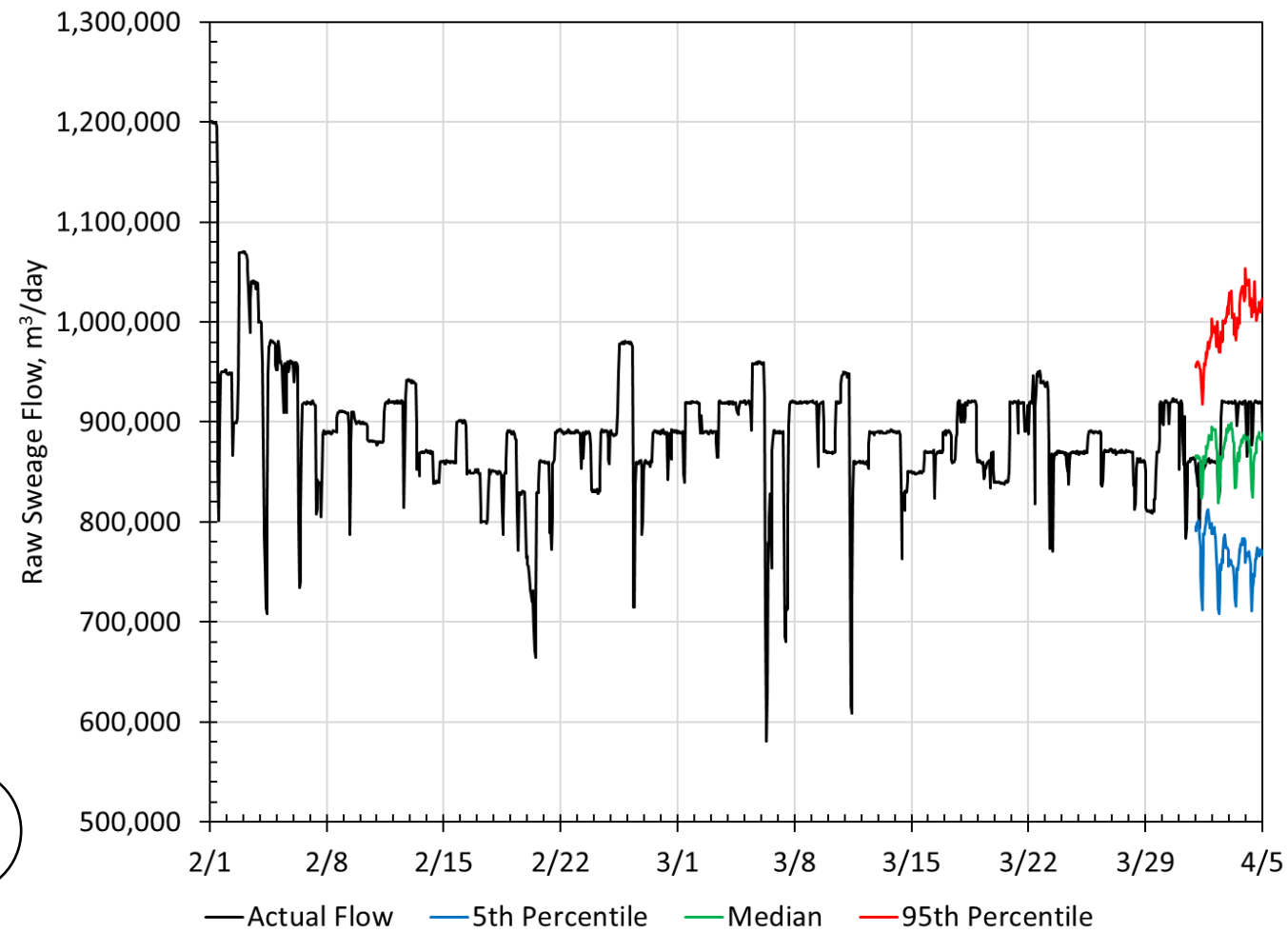
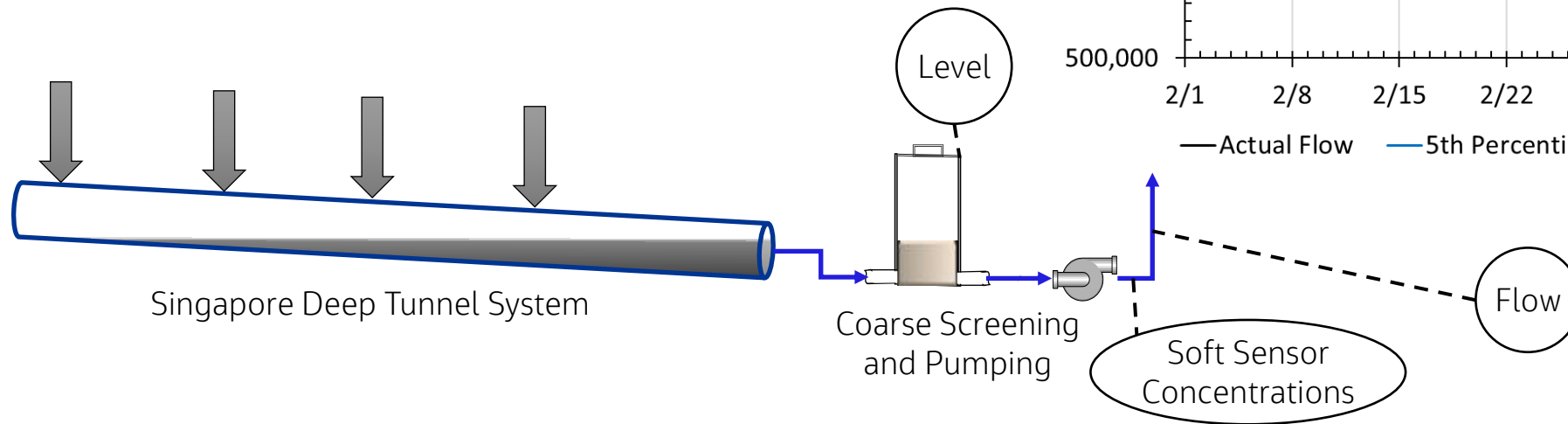

CWRP Influent Flow Forecasting

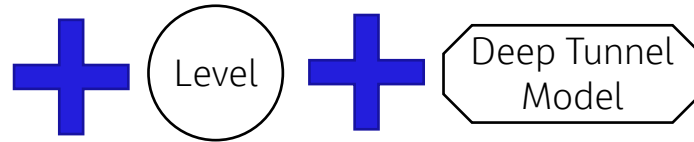
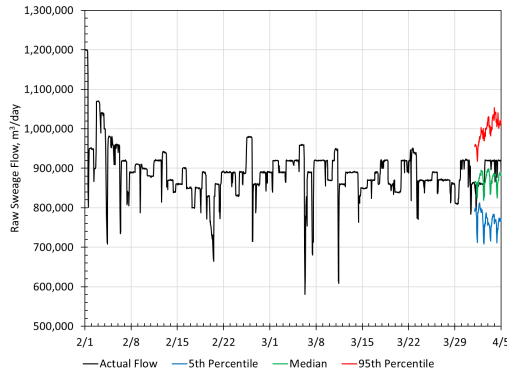

Normal Diurnal Influent Flows to Deep Tunnel

- The “Normal” Historical Influent Diurnal is then used to predict future diurnal flows into the deep tunnel sewer
- Then Deep Tunnel Model and fitted Pump station model is used to predict many possible influent flow patterns into CWRP

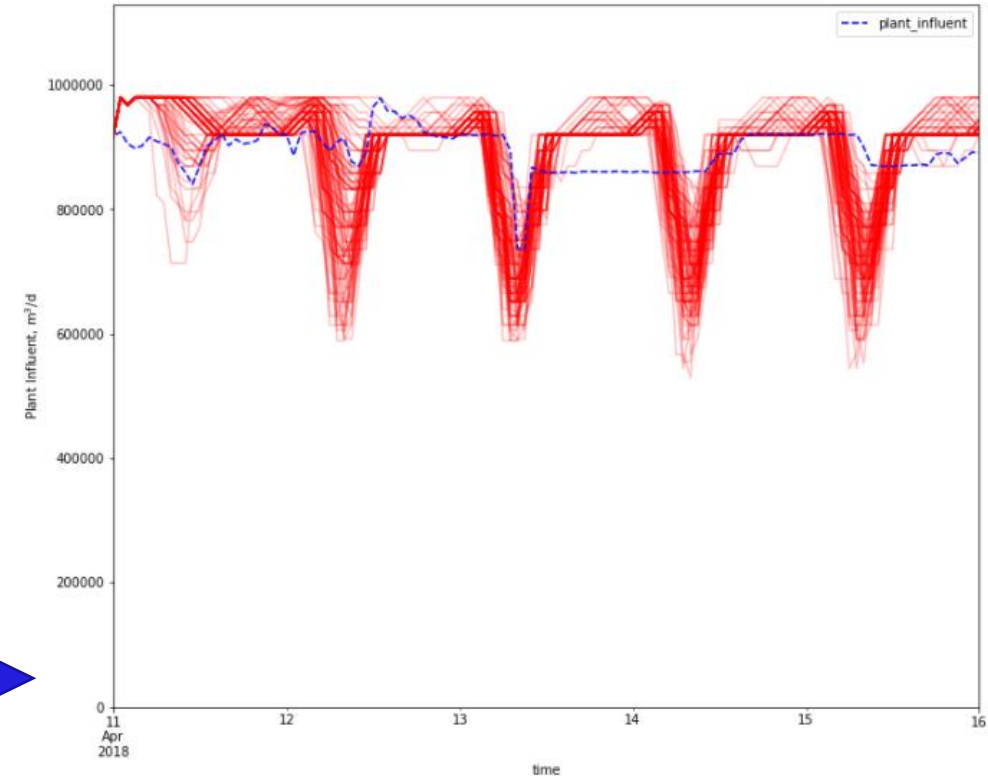

CWRP Influent Concentration Forecasting

- What about loads/concentrations?
- A similar approach is taken to “back out” normal diurnal influent loads entering the deep tunnel system
- The tunnel model is then used to equalize and combine the flow and load data to provide pumped influent concentrations

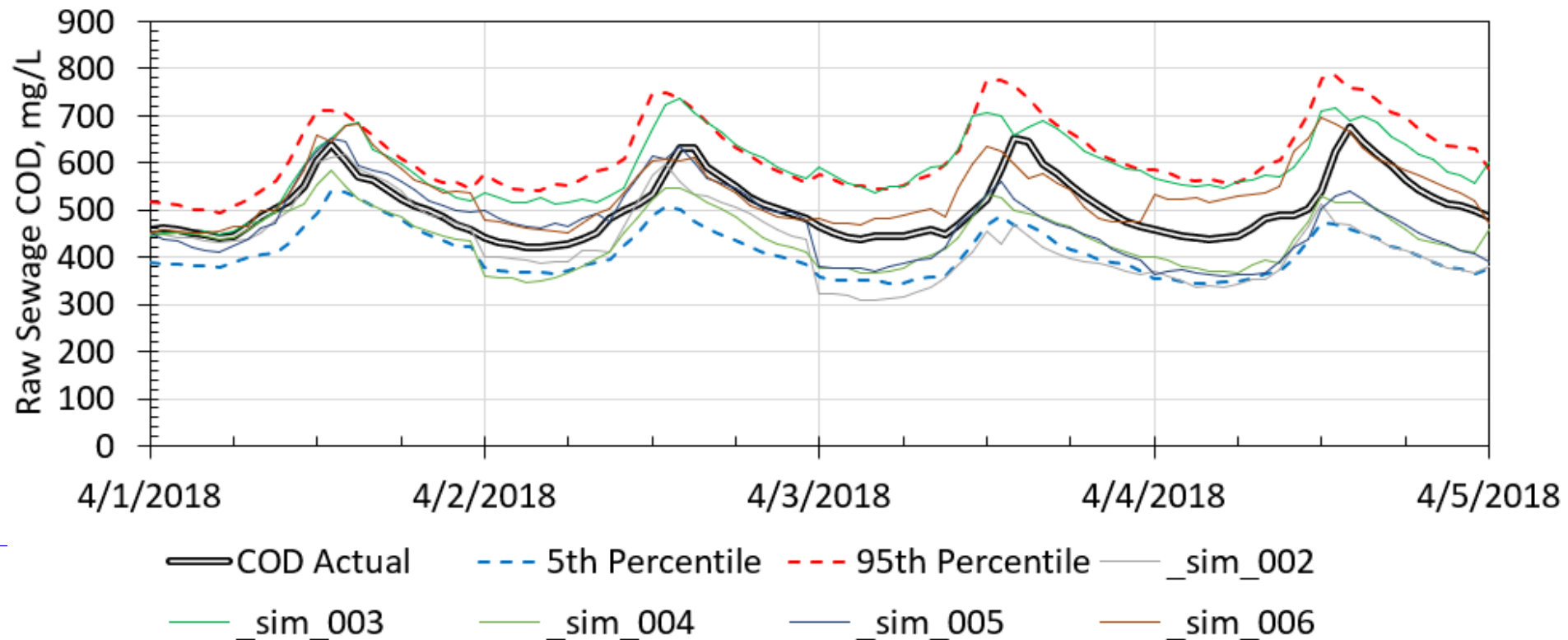

CWRP Digital Twin Forecast Data Path

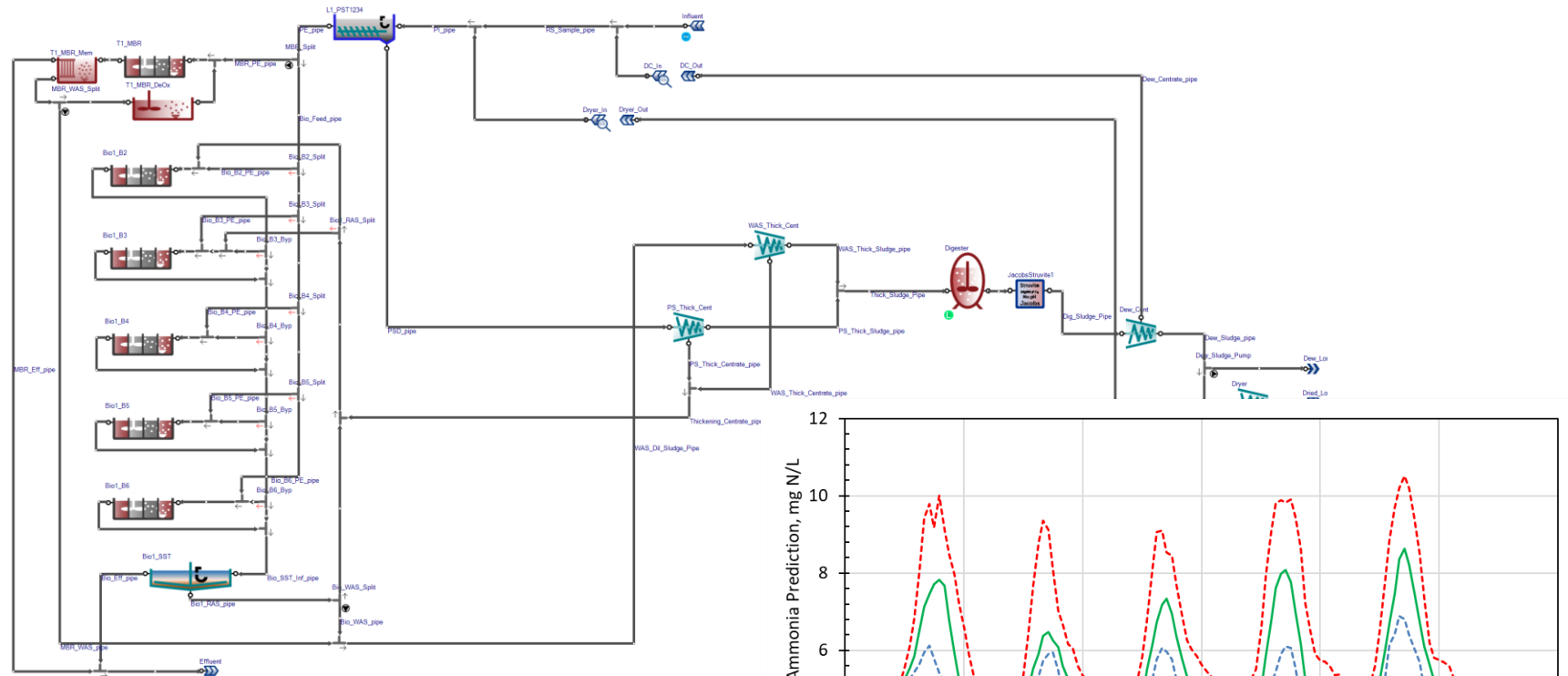
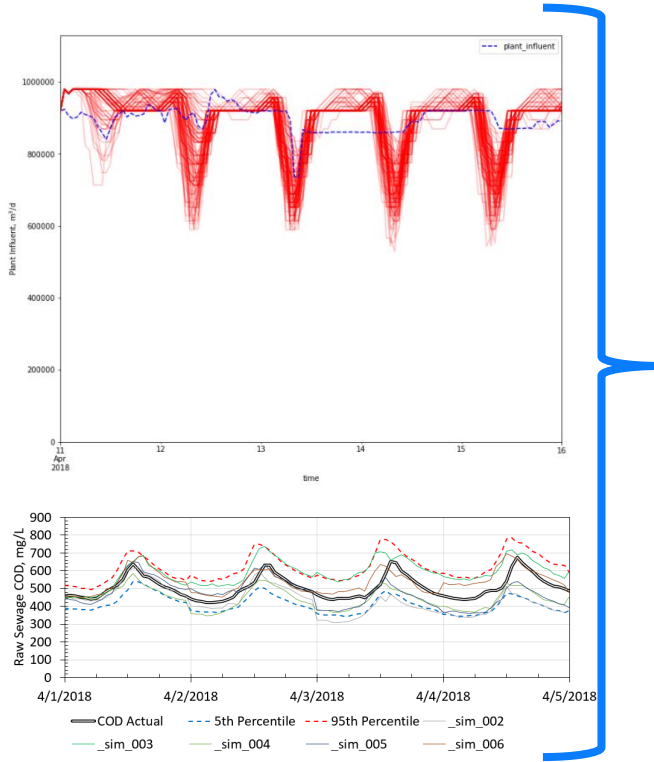

SARIMA
Generated
Influent Profiles

SUMO CWRP
Process Model

Probabilistic
Performance
Forecasts

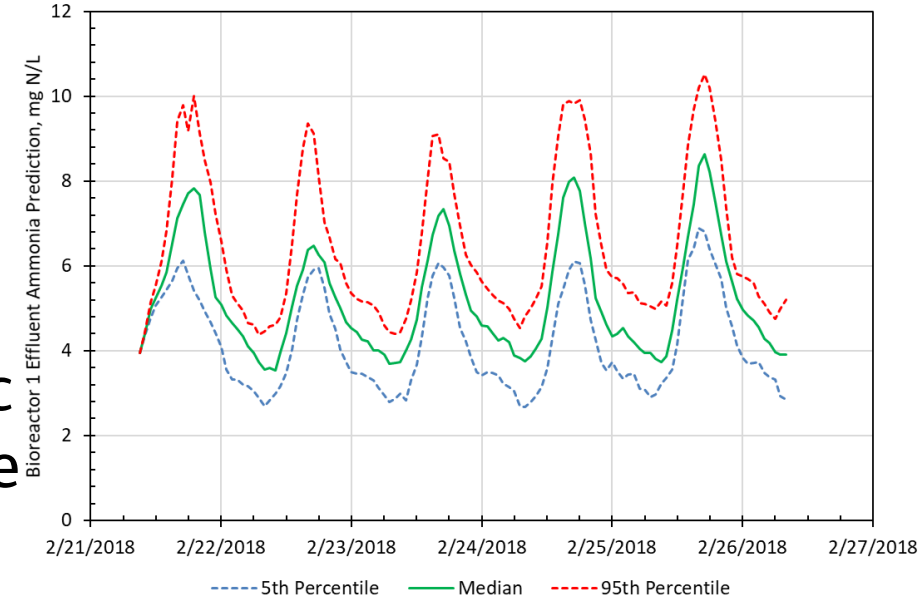

CWRP Forecast Examples from Graphical User Interface (GUI)

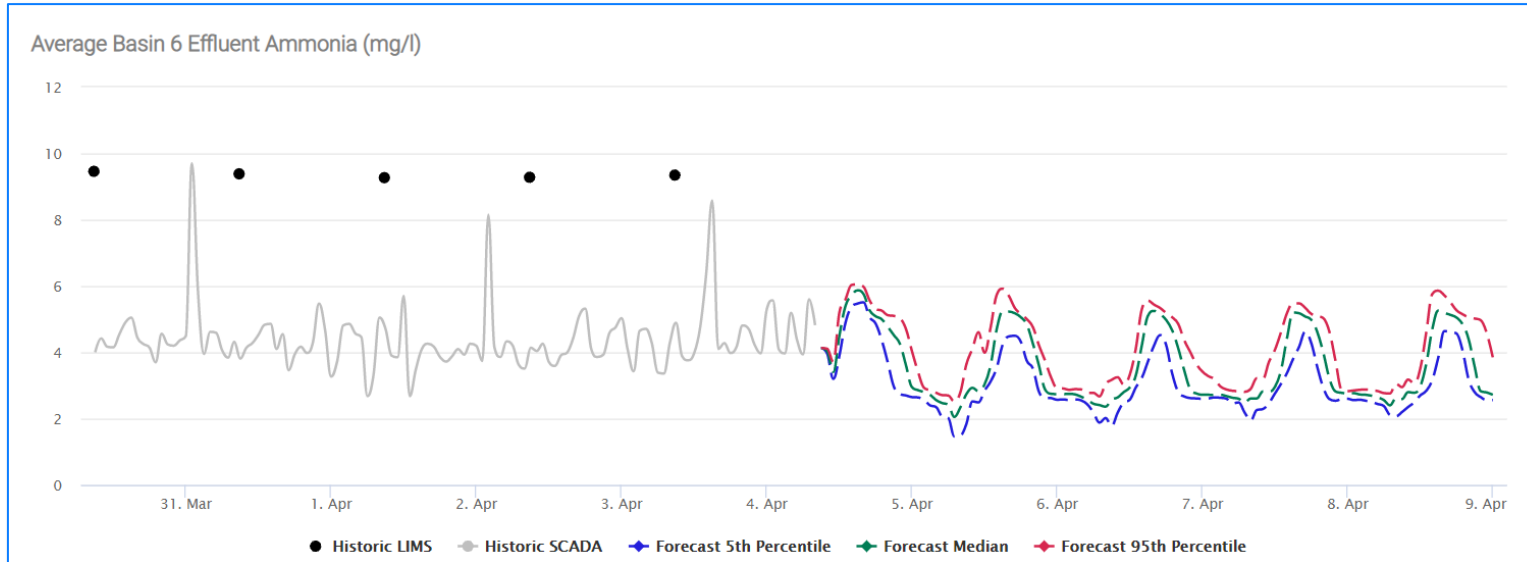

- 5thile = Dashed Blue
- Median = Green
- 95thile = Dashed Red

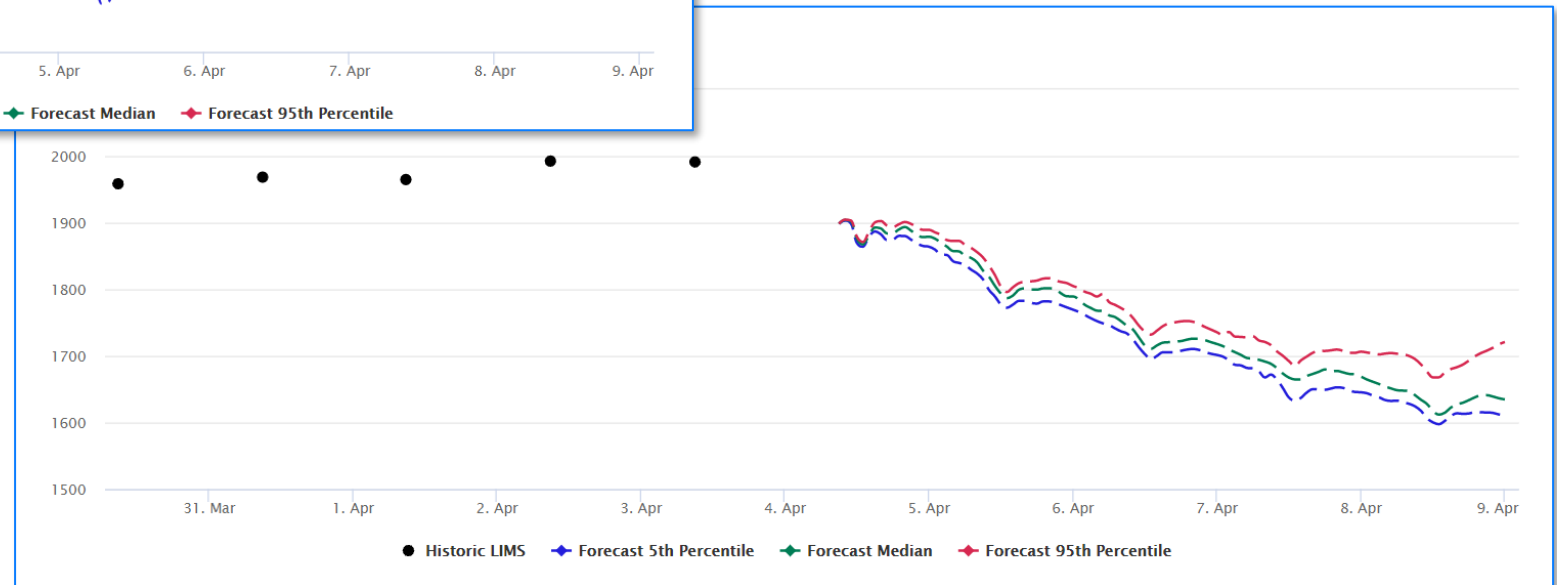

Current Status

- The digital twin will not have any direct control authority and operate in an ADVISORY ONLY mode (for now)
- It is important that the trust of management and operations is in place prior to any active control functions
- COVID...
 - The CWRP Digital Twin servers were installed in February at CWRP
 - Secure automated data transfer on pause due to SCADA Upgrade

Conclusions

Changi WRP Digital Twin replicates all significant aspects of a facility on a digital platform, Hydraulics, I&C, Process

Benefits:

- **Increasing Productivity** with:
Real-time operation insights and process trouble-shooting.
- **Enhancing Resilience of Operations** by:
Moving from Reactive to Proactive
- **Optimize critical operation scenarios**

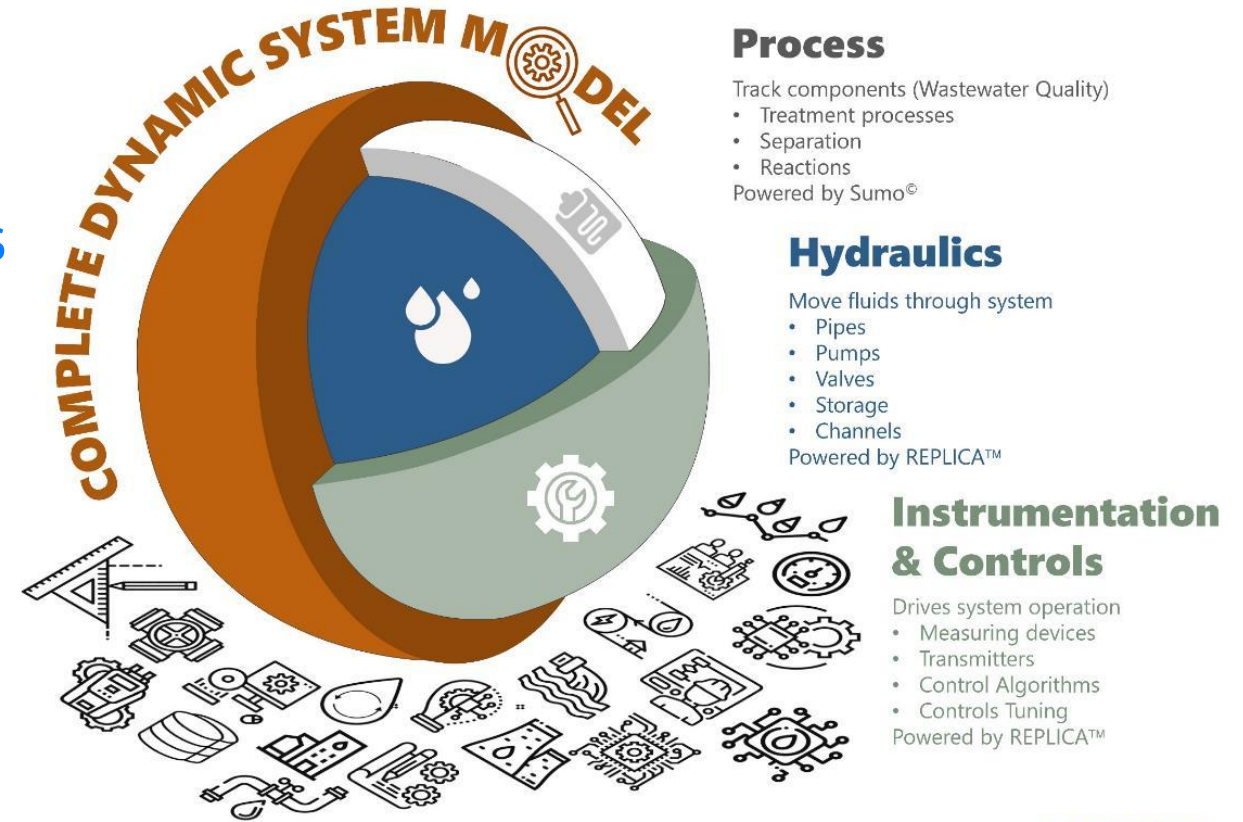

JACOBS

Acknowledgments

- This research is supported by the National Research Foundation, Singapore, and PUB, Singapore's National Water Agency under Urban Solutions & Sustainability (CRP(Water) RFP 1803 <PUB-1803-0014>)
- This work could not have been accomplished without the extensive support, feedback, and contributions from PUB staff and a large team of Jacobs employees in both Singapore and the US

Changi AWTP Digital
Twin Project
International Water
Association's (IWA)
Project Innovation
Gold Award 2022 in
Performance
Improvement and
Operational
Solutions Category



What is Next?

The Water Research Foundation (WaterRF) Research Project

- WaterRF released an RFP in Fall of 2021
 - Development of Innovative Predictive Control Strategies for Nutrient Removal (RFP 5121)
- Proposal based upon the team's experience and the CWRP Digital Twin
- Project Requirements
 - Develop artificial intelligence (AI)/machine learning (ML) predictive tools for nutrient removal
 - Demonstrate testing of new predictive control strategies with field testing at ~~one~~ four utilities
 - This field testing will be complemented by desktop analysis comparing predictive and reactive control strategies

Agency Partners

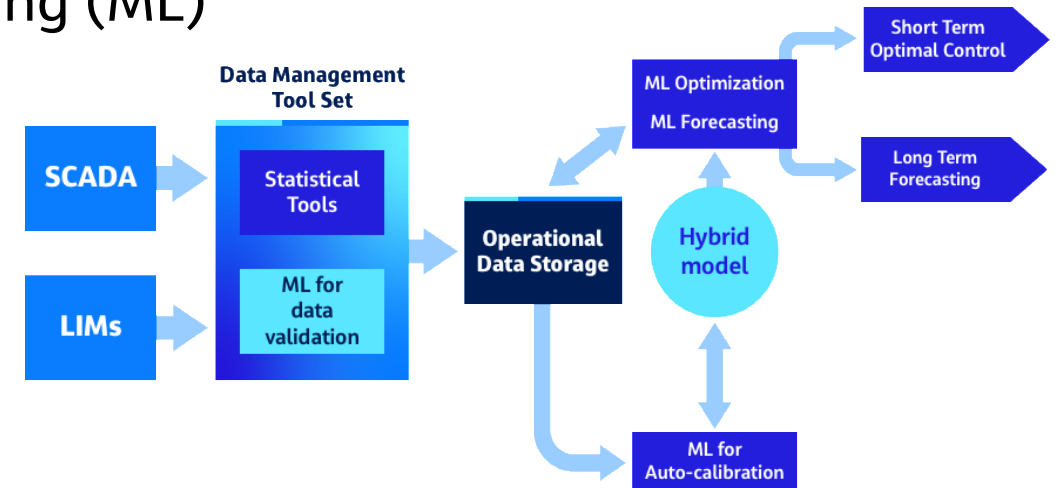

QUESTIONS?

Digital Twin Development Implementation, and Results for the Changi WRP, Singapore

Bruce R. Johnson, PE, BCEE, IWA Fellow

MWRDGC: October 28th, 2022